

Foxboro Model 83F Flanged Body Vortex Flowmeters

Foxboro Model 83W Wafer Body Vortex Flowmeters

with 4 to 20 mA Analog and Pulse Outputs

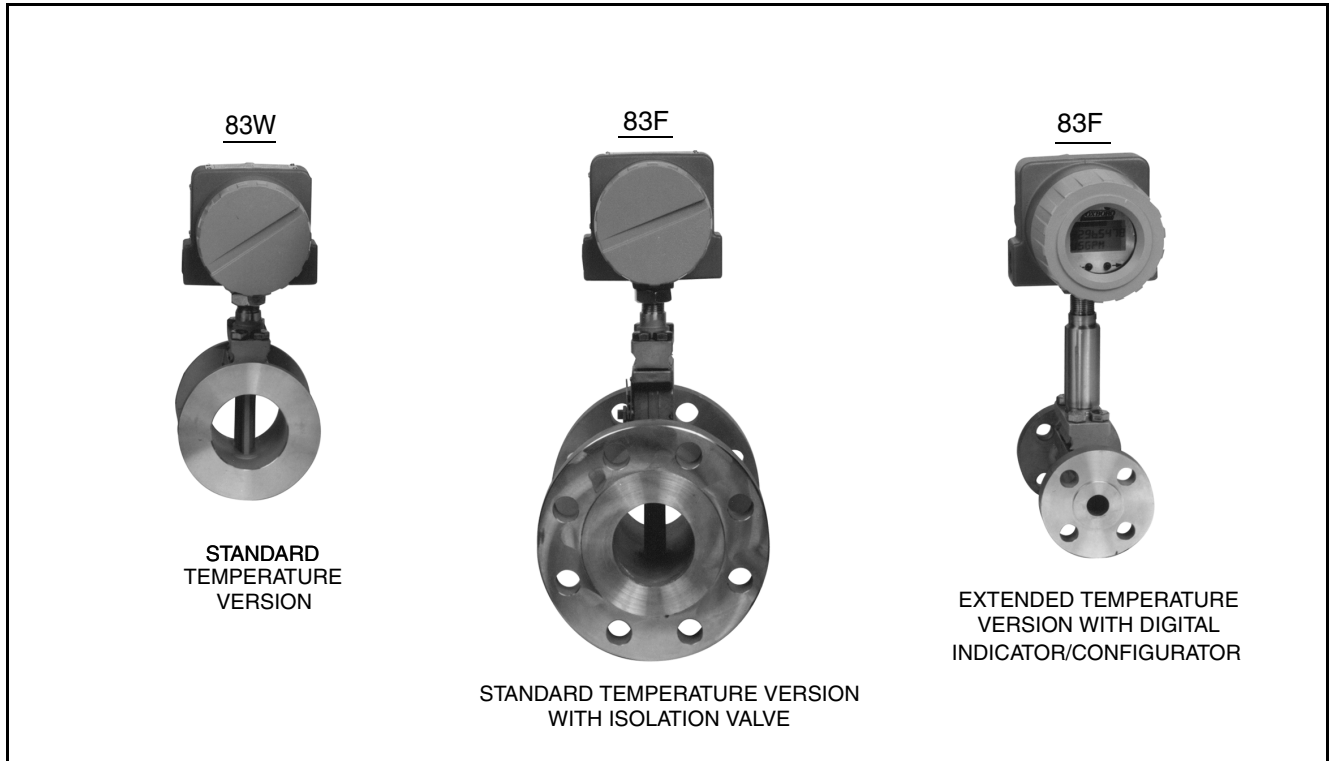

The Models 83F-A and 83W-A are part of a family of high performance, flanged and wafer body vortex flowmeters. They transmit a user-selectable 4 to 20 mA analog or a pulse output signal. An on-board flowrate indicator is provided with a selection of scales for either the analog or pulse output.

FEATURES

- Used on liquids, gases, and steam.
- 4 to 20 mA and pulse flowmeter outputs; user-selectable.
- Outputs compatible with all types of totalizing and control loops.
- Rangeability up to 100:1.
- Wide temperature range up to 800°F (430°C).
- Field adjustable low flow cut-in selections.
- Pulse train smoothing enhances low flow measurement.
- Isolation valve offered to allow sensor replacement without interrupting flow in pipe.
- Rapid response time.
- Temperature K-factor correction.
- Flow rate indicator with a selection of scales for both 4 to 20 mA and pulse output.
- Dual measurement capability (83F only).
- Hastelloy C or stainless steel bodies and flanges.
- FlowExpertPro™ sizing program greatly simplifies flowmeter selection.
- Can be used in hazardous area locations.
- A very wide selection of sizes:
 - Flanged Body: 3/4 to 12 in (DN 15 to DN 300)
 - Water Body: 3/4 to 8 in (DN 15 to DN 200)
- Conforms to applicable European Union directives (including PED).

LIFETIME WARRANTY

Sensor Warranty against workmanship and material defects for lifetime of flowmeter – contact Invensys Foxboro.

FlowExpertPro™

FlowExpertPro is a program primarily used to size Foxboro flowmeters. It also ensures that the user has selected the proper flowmeter type for his application. Invensys provides this meter selection tool as a free web site to all users, without the need for registration. In addition to flowmeter selection and sizing, FlowExpertPro includes the following features:

- Incorporates a large library of the physical properties of typical process fluids.
- Displays results in tabular or graphic format.
- Allows user to save, print, or E-mail results.
- Provides reference to applicable flowmeter PSSs and other related flowmeter documentation.

The program calculates minimum and maximum flow rates, rangeability, pressure loss, and Reynolds Number, using established flow equations. It also allows for material and flange selection, and provides ANSI or metric flange recommendations for predicted flow pressures and temperatures. You are invited to visit www.FlowExpertPro.com to access this program, or contact Invensys for further information, and technical support.

HIGH PERFORMANCE AT LOWER COST

The Invensys Foxboro patented family of vortex flowmeters has the high accuracy and rangeability of positive displacement and turbine flowmeters without the mechanical complexity and high cost. Maximum rangeability up to 100:1 is possible as compared to 3:1 for a nonlinear differential pressure producer (orifice plate). Because these Flowmeters have no moving parts, they are very durable and reliable. This simplicity of design ensures low initial cost, low operating and maintenance costs, and therefore contributing to an overall low cost of ownership.

SIMPLIFIED START-UP

Invensys Foxboro pre-configures the flowmeter using flow data supplied by the customer. No primary device calculations or mechanical calibrations are required if the flow data is supplied when placing the order. This allows the user to simply install the flow-calibrated flowmeter and connect wiring to the proper power source and readout or control instrumentation, and the 83F-A or 83W-A is ready to measure flow.

When flow data is not provided, flowmeter is shipped partially configured. On-site configuration can be completed using easily accessible DIP-switches.

OUTPUT IS COMPATIBLE WITH ALL TYPES OF TOTALIZING AND CONTROL LOOPS

These flowmeters transmit two different types of output signals that are linearly proportional to volumetric flow rate. The flowmeters produce a pulse rate signal for totalizing and batching, or an electronic analog 4 to 20 mA dc signal for recording and control of flow rate.

OTHER Foxboro VORTEX FLOWMETERS (Table Below)

Model	Description	Output	Reference
83F-D	Flanged	FoxCom or Pulse	PSS 1-8A1 E
83W-D	Wafer		
83F-T	Flanged	HART or Pulse	
83W-T	Wafer		
83F-F	Flanged	FOUNDATION Fieldbus	PSS 1-8A1 F
83W-F	Wafer		
83S-D	Sanitary	FoxCom or Pulse	PSS 1-8A2 D
83S-T	Sanitary	HART or Pulse	
83S-A	Sanitary	4 to 20 mA or Pulse	PSS 1-8A2 E
84F-T	Flanged	HART or Pulse	PSS 1-8A3 A
84W-T	Wafer		
84S-T	Sanitary	HART or Pulse	PSS 1-8A5 A

WIDE VARIETY OF APPLICATIONS

The 83F Flowmeter is available in 3/4 to 12 in (DN 15 to DN 300) line sizes. The 83W Flowmeter is available in nominal 3/4 to 8 in (DN 15 to DN 200) line sizes. Water velocities (at standard conditions) up to 25.3 ft/s (7.7 m/s), and gas or steam velocities up to 600 ft/s (185 m/s) can be measured. These flowmeters set the example for industry standards whether the application requires accuracy for totalizing and batching; utility metering of fluids in the process industries; fuel, air, steam, or gas metering for the measurement of energy in any high use application; or stability and repeatability for process control.

COMPACT, EFFICIENT, AND DURABLE DESIGN

The flowmeter mounts between ANSI or metric raised face flanges. See Model Code section for end connections offered with each line size. Other flange face surfaces can be used as a custom design.

The electronics housing is of explosionproof and flameproof construction and provides environmental protection to the enclosed electronics. It is offered integrally mounted to the flowtube, or can be mounted remotely.

The flowmeter's simple, modular design requires minimum maintenance. Common, field replaceable parts are used, including the sensor assembly and amplifier. The amplifier can be replaced without interrupting the flow in the pipe, and sensor can be replaced without process shutdown when an isolation valve is installed. Since a single device is used for multiprocess-fluid applications, ordering is simplified and spare part needs minimized.

ISOLATION VALVE

An isolation valve allows the sensor to be removed or replaced without interrupting the flow in the pipe.

FLOW RATE INDICATOR

A Flow Rate Indicator is available for both the analog (4 to 20 mA) and pulse output flowmeters. Linear indicator scales, either 0 to 100% or with ten equally spaced divisions, are offered for both output versions. The Flow Rate Indicator is a Model Code Selection.

REMOTE MOUNTED ELECTRONICS HOUSING

Remote mounting is offered to allow access to the amplifier and other housing electronics when the measurement is not in an easily accessible location. The remote housing is supported by a bracket, which in turn mounts to a surface or to a nominal 2-in or DN 50 pipe. This housing can be located up to a cable length of 50 ft (15.2 m) from the flowtube without loss of low level signal.

DUAL MEASUREMENT FLOWMETER (84F ONLY)

Dual Measurement Vortex Flowmeters provide the user with redundant sensors and electronics. Two electronics housings and sensors are mounted to a common flowmeter body assembly. Should one transmitter fail, the redundant measurement avoids the necessity of shutting down the process. The failed transmitter can then be replaced at some later noncritical time. Applications include Safety Shutdown Systems (independent of Process Measurement Network), Safety Backup for critical flow loops, Comparative Verification of Measurement for high accuracy precision loops, or just for dual communications paths with the same primary element.

DESIGNED FOR USE IN HAZARDOUS LOCATIONS

These flowmeters have been designed to meet the approval requirements of many certifying agencies for use in hazardous area locations. Refer to "Product Safety Specifications" section.

CE COMPLIANCE

This family of flowmeters displays the CE designation indicating conformance to the applicable European Community Standards for immunity to sources of electromagnetic interference. This compliance also includes conformance to a maximum level of self-generated electromagnetic energy, and includes PED (Harmonized Pressure Equipment Directive for the European Community). See table below for details.

PED

Invensys Foxboro has elected to offer the PED (Harmonized Pressure Equipment Directive for the European Community) certification only with meters ordered with the ATEX Electrical Safety Code Model Code selections. ATEX electrical certifications are in place for N and E codes. Therefore the CE marking carries the ATEX number.

Meter Size	Electrical Safety Design Code	CE Marking
3/4 and 1 in (DN 15 and DN 25) (a)	N or E	CE 0344
1 1/2 in (DN 40) and larger	N or E	CE 0344, CE 0575

(a) Line sizes 1 inch and smaller are only required to meet SEP - Sound Engineering Practice to be compliant with the PED directive.

OPERATING CONDITIONS(a)

Influence	Calibration Operating Conditions(b)	Normal Operating Condition Limits	Operative Limits
Process Fluid	Clear Water	Liquid	Liquid
Process Temperature	70 to 85°F (20 to 30°C)	0 and 400°F (-18 and +200°C)	0 and 400°F (-18 and +200°C)
Ambient Temperature (Electronics Housing)	70 to 85°F (20 to 30°C)	-40 and +185°F (d) (-40 and +85°C) (d)	-40 and +185°F (d) (-40 and +85°C) (d)
Relative Humidity	50 to 90% RH	0 and 100%	0 and 100%
Supply Voltage: • Pulse • Analog(c)	24 V dc 24 V dc	10.5 and 50 V dc 10.5 and 50 V dc	10.5 and 50 V dc 10.5 and 50 V dc
Loop Load: • Pulse • Analog(c)	R = 100 kΩ C = 0 μF 300 Ω (c)	R = 100 kΩ C = 0.05 μF 0 and 1925 Ω (c)	R = 10 kΩ min, C = 0.05 μF 0 and 1925 Ω (c)

- (a) Limited to nonflashing, noncavitating conditions. Flow rate and temperature of process may induce flashing and cavitation which is dependent on pressure drop and process vapor pressure. A minimum positive back-pressure is required for proper operation.
- (b) Assumes compatible process piping and fittings; gaskets not protruding into process line; a minimum of thirty pipe diameters of straight pipe upstream of flowmeter and eight pipe diameters downstream; clear water free of air or particles.
- (c) The loop load can vary as listed, depending on the supply voltage used. See Figure 2 for a plot of supply voltage vs. loop load.
- (d) Refer to Electrical Safety Specifications section for a restriction in ambient temperature with certain electrical certifications.

PERFORMANCE SPECIFICATIONS

(Under Calibration Operating Conditions unless Otherwise Stated)

Factory Calibrated Flow Ranges

Nominal Meter Size	Nominal Mean K-Factor in Pulses/ft ³ (Pulses/L) (a)	Factory-Calibrated Flow Range for Water (c)		
		Range in US gpm	Range in L/s	Reynolds Number Range
3/4 in (DN 15)	5580 (197)	6.9 to 34	0.43 to 2.1	30 000 to 150 000
1 in (DN 25)	2250 (79.5)	8.9 to 56	0.56 to 3.5	30 000 to 190 000
1 1/2 in (DN 40)	570 (20.1)	14 to 140	0.88 to 8.7	30 000 to 300 000
2 in (DN 50)	258 (9.11)	18 to 230	1.1 to 15	30 000 to 380 000
3 in (DN 80)	78.7 (2.78)	34 to 500	2.1 to 32	38 000 to 570 000
4 in (DN 100)	34.8 (1.23)	59 to 890	3.7 to 56	50 000 to 750 000
6 in (DN 150)	10.00 (0.353)	140 to 2000	8.5 to 130	76 000 to 1 100 000
8 in (DN 200)	4.26 (0.150)	240 to 3600	15 to 220	100 000 to 1 500 000
10 in (DN 250) (b)	1.99 (0.0703)	390 to 5800	24 to 370	130 000 to 1 900 000
12 in (DN 300) (b)	1.16 (0.0410)	560 to 8400	36 to 530	160 000 to 2 300 000

- (a) The K-factor is the relationship between input (volumetric flow rate) and the output (pulse rate).
Reference K-factor: The arithmetic mean value of K-factor over a designated flow rate range (reference conditions).
The mean K-factor is derived as:
Mean K-factor = (KMAX + KMIN) / 2
Where KMAX is the Maximum K-factor and KMIN is the Minimum K-factor over the calibrated flow range.
- (b) The 10 and 12 in (DN 250 and DN 300) flowmeters are available with the Model 83F only.
- (c) Factory calibrated Reynolds Number range applies to standard temperature sensor without isolation valve. Other sensor selections and manifold selections may alter the calibration range. See FlowExpertPro for specific calibration ranges.

PERFORMANCE SPECIFICATIONS (Cont.)

Accuracy - General

The accuracy of the meters, stated in next paragraphs, is under calibration operating conditions (see Operating Conditions table). Installation parameters such as location of valves, proximity to elbows, etc., will affect the accuracy of the flow measurement. Data is presented in MI 019-189 to correct the measurement for these effects.

The accuracy below 20 000 R_D is not specified because the K-factor deviates from its reference value at low flows. For applications below 20 000 R_D , the I/A Series Intelligent Vortex Flowmeter is recommended. See PSS 1-8A1 E.

Accuracy for Liquids (see Figure 1 and NOTE)

Accuracy within factory-calibrated Reynolds Number range is $\pm 0.5\%$. Outside the calibrated range, the accuracy is $\pm 1\%$ of reading for flow rates with Reynolds Number of 20 000 or greater.

Accuracy for Gases and Steam (see NOTE)

Accuracy is $\pm 1\%$ of reading for flow rates with Reynolds Number of 20 000 or greater.

NOTE

To achieve the accuracies stated for the fluids above, the flowing density and viscosity must be input during meter configuration.

Relative Humidity Effect

There is no effect due to relative humidity as long as the covers and seals are properly installed.

Process Liquid Viscosity Effect

The viscosity of liquids must be known when choosing a vortex flowmeter for low flow applications. High viscosity will reduce the ability of the flowmeter to measure low flow. Below R_D 30 000, the accuracy is affected by an increasing positive linearity error reaching about $+2\%$ at 10 000 R_D . Below an R_D of 10 000, accuracy is not easily predictable - however, calibration of a given flowmeter is repeatable. An indication of flow may be possible to as low as 5 000 Reynolds Number. Use the FlowExpertPro Sizing Program for process viscosity/Reynolds Number limits.

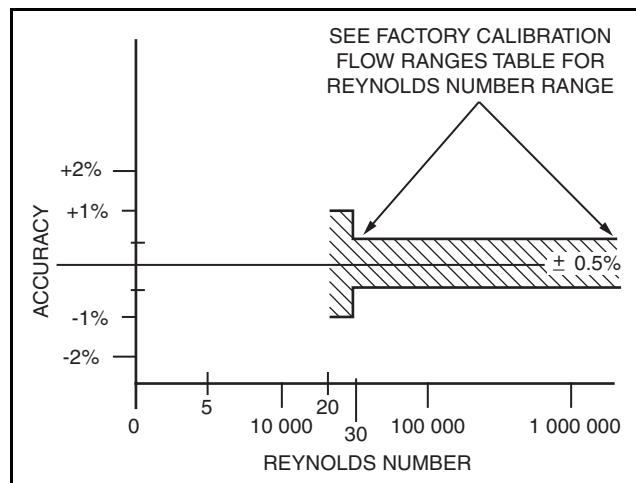

Figure 1. Flowmeter Accuracy for Liquids

Flow Overrange Effect

Overranges beyond 25% of maximum velocity could result in sensor damage with subsequent loss of signal.

WITH PULSE OUTPUT

No significant effect on accuracy or loss of signal.

WITH ANALOG OUTPUT

Analog signal is limited to 20 mA dc maximum, and, therefore, may not reproduce true flow rate measurement above 20 mA.

Process Temperature Effect on K-Factor

The K-factor reference is factory-determined at reference conditions. When the actual process temperature is provided, Invensys Foxboro calculates the flowing K-factor to correct for temperature effects. Calculation procedures to manually change the flowing K-factor are contained in Master Instruction MI 019-189.

Ambient Temperature Effect (Amplifier only)

WITH PULSE OUTPUT

No pulse rate change above low flow cut-in.

WITH ANALOG OUTPUT

For 55°C (100°F) change in ambient temperature within operative limits.

Zero (4 mA): $\pm 0.25\%$ of span maximum

Span (16 mA): $\pm 0.25\%$ of span maximum

Supply Voltage Effect (Within Stated Limits)

WITH PULSE OUTPUT

No effect on accuracy

WITH ANALOG OUTPUT

Less than 0.01% per 1.0% voltage change.

PERFORMANCE SPECIFICATIONS (Cont.)

Vibration Effect

Vibration can affect the flow measurement output of a Vortex flowmeter in the form of added pulses, but with the built-in Tuning functions and Low Flow Cut-in adjustability, these effects can be minimized. Invensys Foxboro has tested this meter with vibrations up to 3 “g” of acceleration with no physical damage, no shift in calibration after the test, and no loss of communications throughout the test.

Emission Effect

Radiated and conducted electromagnetic emissions meet the requirements of North America and NAMUR.

Electromagnetic Compatibility (RFI)

The output error from RFI at radio frequencies ranging from 27 to 1 000 MHz is less than $\pm 1\%$ of span at a field intensity of 10 V/m; and less than $\pm 2\%$ of span at a field intensity of 30 V/m. This applies only when the electronics housing is properly earthed (grounded).

Position Effect (Filled Pipe Conditions)

For most applications, the flowmeter can be mounted in a pipeline which may run in any direction from the vertical (flow in upward direction) to the horizontal. Measurement of liquid and gas streams is not affected by the pipeline orientation or the flowmeter orientation in the pipeline.

For saturated steam, the recommended flowmeter position is in a horizontal pipe with the electronics housing located below the pipeline.

For superheated steam, the flowmeter is usually best mounted in a horizontal or inclined pipe with the electronics housing located above the pipeline. Measuring superheated steam in vertical pipelines requires that the electronics housing and sensor compartment be free of intermittent condensate. It is recommended that the sensor be insulated to insure at least 10°F (6°C) of superheat.

Refer to recommended Mounting Arrangements section for further information.

FUNCTIONAL SPECIFICATIONS

Output Signal

PULSE OUTPUT

Square wave voltage equals supply voltage minus two volts. Maximum current is 10 mA (sink or source). Shielded and twisted cable is recommended.

ANALOG OUTPUT

4 to 20 mA dc into a maximum of 1925 Ω depending on power supply. See Figure 2.

Power Supply Requirements

PULSE MODE

Supply Voltage Limits: See Figure 2.

Supply Current: 15 mA dc.

ANALOG MODE

Supply Voltage Limits: See Figure 2.

Supply Current: 22 mA dc

European Union Directives

- Complies with Electromagnetic Compatibility Requirements of European EMC Directive 89/336/EEC by conforming to the following CENELEC and IEC Standards: EN 50081-2, EN 50082-2, EN 61326, and IEC 61000-4-2 through 61000-4-6.
- Complies with NAMUR NE 21 Interference Immunity Requirement (EMC).
- Conforms to Applicable European Union Directives (“CE” Logo marked on product).

Low Flow Cut-in Adjustment

Pulse and analog versions have low flow cut-ins to optimize amplifier performance as a function of fluid density and minimum fluid velocity. Field-adjustable by low flow cut-in switches. Flow rate settings will change by a nominal factor of 2 for each sequence of cut-in switch position.

Span Adjustment

Not required for pulse version. For analog version, the output is factory set and is field-adjustable with coarse and fine span potentiometer.

Zero Adjustment

No suppression or elevation. The analog output version is factory set to 4.00±0.01 mA and has a potentiometer to adjust the zero to 4.00 mA.

Reference K-Factor

The reference K-factor is a coefficient that specifies the flowmeter calibration and is expressed as the ratio of pulses per unit volume, where pulses/unit volume = pulses per second divided by volume flow per second. The reference K-factor is the specific factor for a given flowmeter body and is the arithmetic mean value of K over the factory-calibrated flow range.

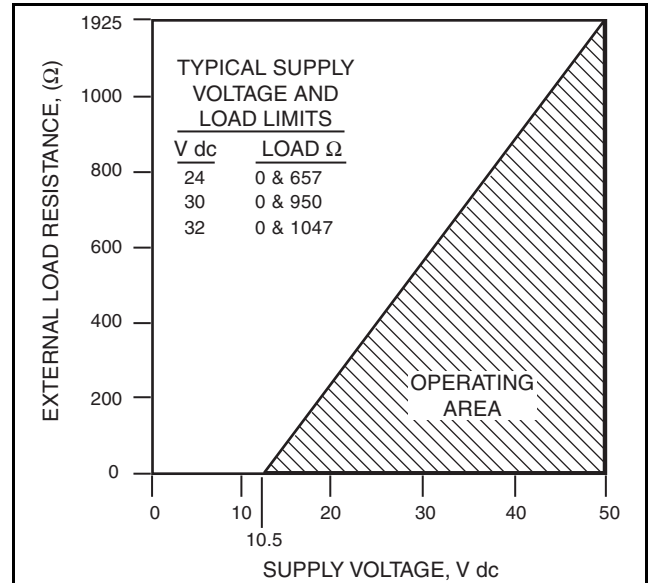

Figure 2. Supply Voltage vs. Load Resistance

Reference K-Factor Determination

The reference K-factor is determined at the factory flow facility by actual flow calibration with water by comparison to a master flowmeter calibration or by actual static weight. Both calibrations are traceable to NIST (National Institute of Standards and Technology). The reference K-factor embedded in the flowmeter data base and is stamped on the data plate.

Flowing K-Factor

The flowing K-factor is computed from the K-reference expressed in specific flowing units, and can be corrected for the following:

- Process Temperature
- Mating Pipe
- Upstream Disturbances

Nominal Flow Velocity Limits

These limits can be calculated using Table 1 below. In the table, ρ_f is the process fluid density at flowing conditions in lb/ft³ or kg/m³, as applicable. The specifications apply for most applications, but can deviate slightly for some combinations of density and line size. Also refer to FlowExpertPro.Com.

Table 1. Nominal Flow Velocity Limits

Range Limit	Std. Temperature Range		High Temperature Range	
	ft/s	m/s	ft/s	m/s
Lower	2.0/√ρ _f	2.4/√ρ _f	4.0/√ρ _f	4.8/√ρ _f
Upper	200/√ρ _f	240/√ρ _f	200/√ρ _f	240/√ρ _f

FUNCTIONAL SPECIFICATIONS (Cont.)
Flowmeter Rangeability

The flowmeter has an enhanced rangeability compared to other Vortex Flowmeters due to its lower LFCI capability and improved frequency filtering. Rangeability of up to 100:1 is achievable.

Flowmeter Ranges

Flowmeter is shipped with flow range specified in the sales order or with a default flow range equal to the meter capacity. It can be reranged by the user keeping the same flowrate units, choosing new flowrate units from a built-in menu-selectable list, or entering custom flowrate units. Also refer to FlowExpertPro.Com.

Static Pressure Limits**MINIMUM**

The minimum static pressure is that pressure which is sufficient to prevent flashing, and meet the pressure drop requirements to attain maximum flow rate. Refer to FlowExpertPro sizing programs.

MAXIMUM

1500 psi (10 340 kPa) or that imposed by flange rating piping.

Approximate Pressure Loss (Pressure Drop)

The maximum pressure loss at maximum flow for every flowmeter with any fluid is 8 psi (55 kPa). For many flow conditions, however, the actual pressure loss is much less than 8 psi (55 kPa). Use the FlowExpertPro Sizing Program to determine actual pressure loss for a given set of conditions.

Minimum Back Pressure (Volatile Liquids or Low Pressure Conditions)

Any condition that tends to contribute to the release of vapor from the liquid (flashing, which may also induce cavitation) shall be avoided by proper system design and operation of the flow-meter within the rated flow rate range. Location of flowmeter should determine the need for incorporating or considering a back-pressure valve, or for increasing inlet pressure. To avoid flashing and to ensure stable vortex generation, the minimum back pressure should be:

$$P_G = (3)(\Delta P) + (1.25)(p_v) - (p_{atm})$$

where

P_G = Gauge pressure in psi or kPa five pipe diameters downstream of the flowmeter

ΔP = Calculated pressure loss in psi or kPa (see "Approximate Pressure Loss" section)

p_v = Vapor pressure at line conditions in psi or kPa absolute

p_{atm} = Atmospheric pressure in psi or kPa absolute

Flange Pressure-Temperature Ratings

See Figures 3 to 8 for ANSI and metric flange pressure-temperature ratings. Also see Figure 9 for pressure-temperature limits when isolation valves are used. Also note the temperature limit when fluorolube fill (200°F/90°C) or silicone fill (400°F/200°C) is used, or when no fill (800°F/430°C) is used with extended temperature applications. The flange ratings in Figures 3 through 8 are also embedded in the FlowExpertPro sizing program.

FUNCTIONAL SPECIFICATIONS (Cont.)

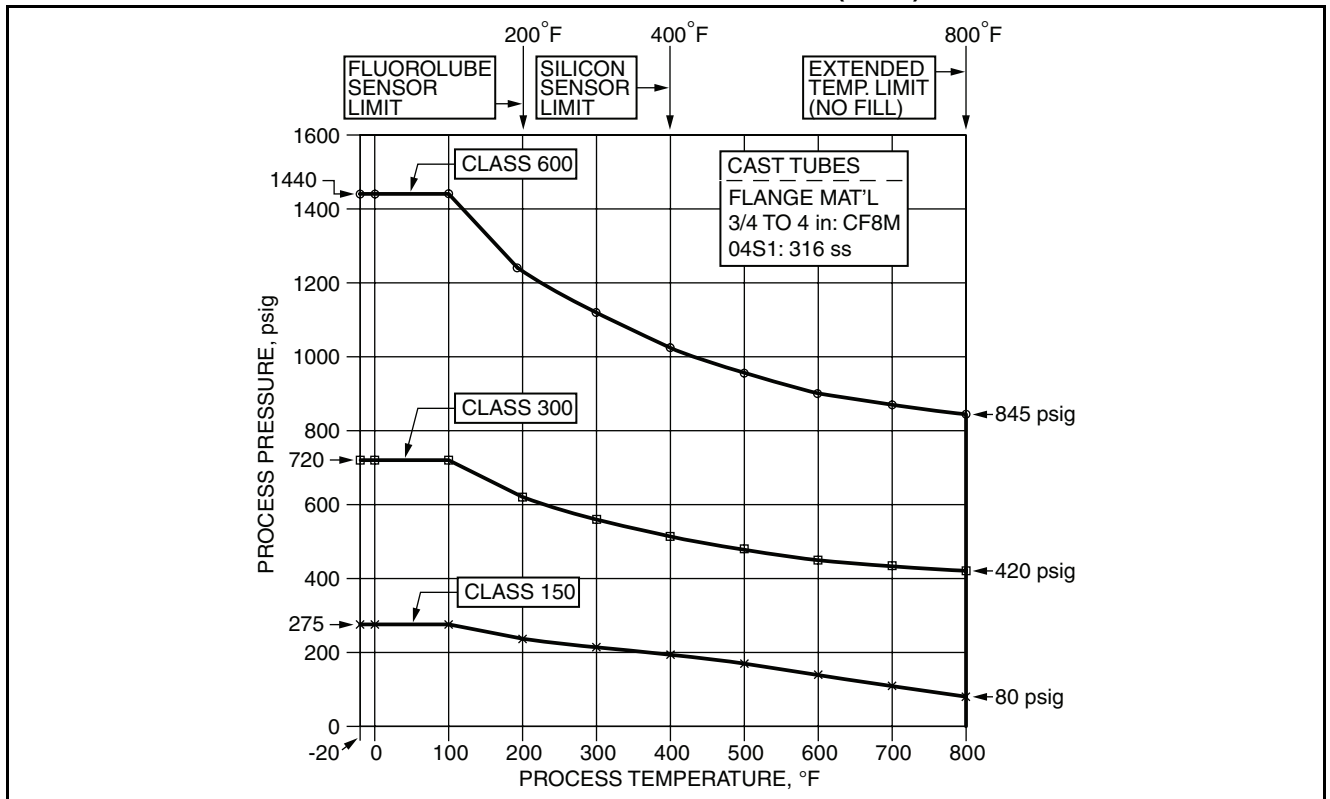

Figure 3. ANSI Flange Ratings; per ASME B16.5; Group 2.2 Materials

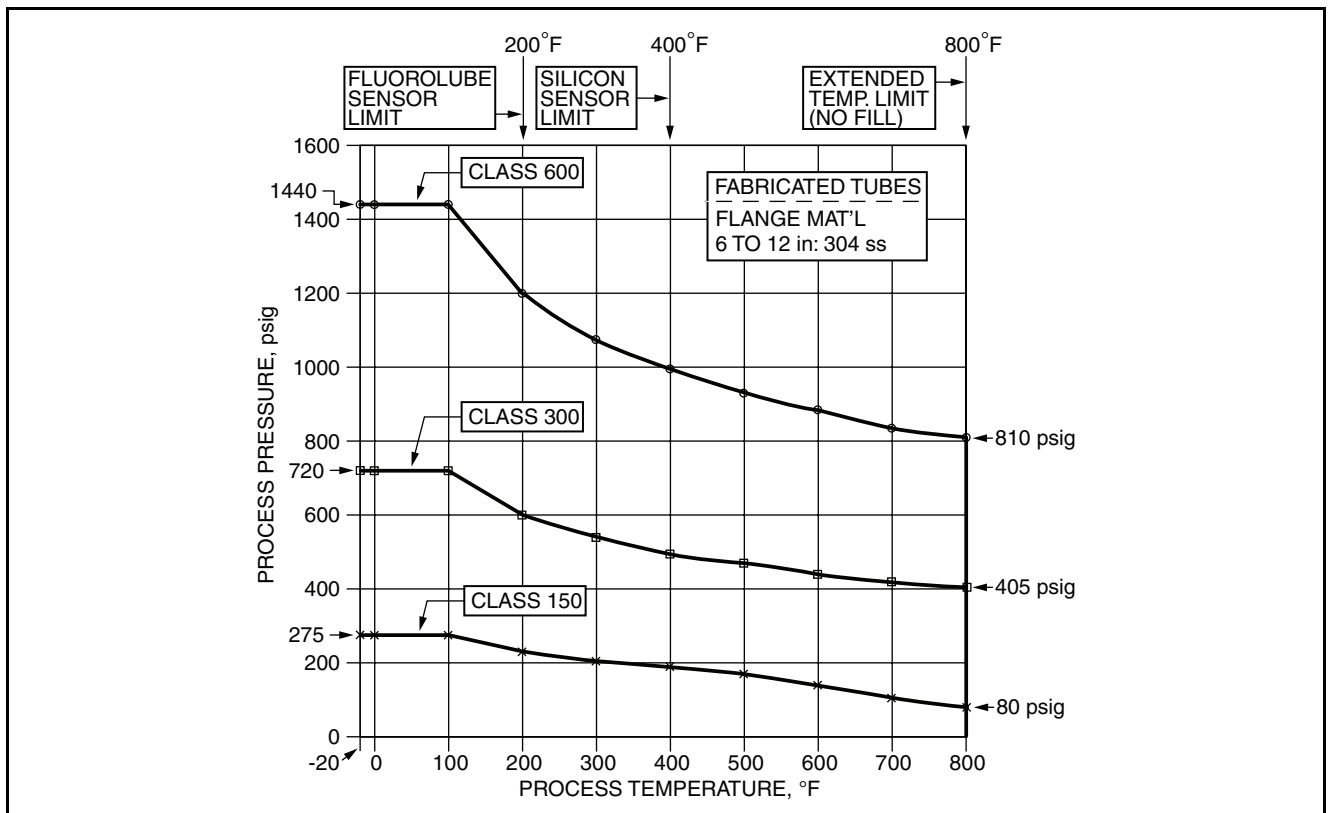

Figure 4. ANSI Flange Ratings; per ASME B16.5; Group 2.1 Materials

FUNCTIONAL SPECIFICATIONS (Cont.)

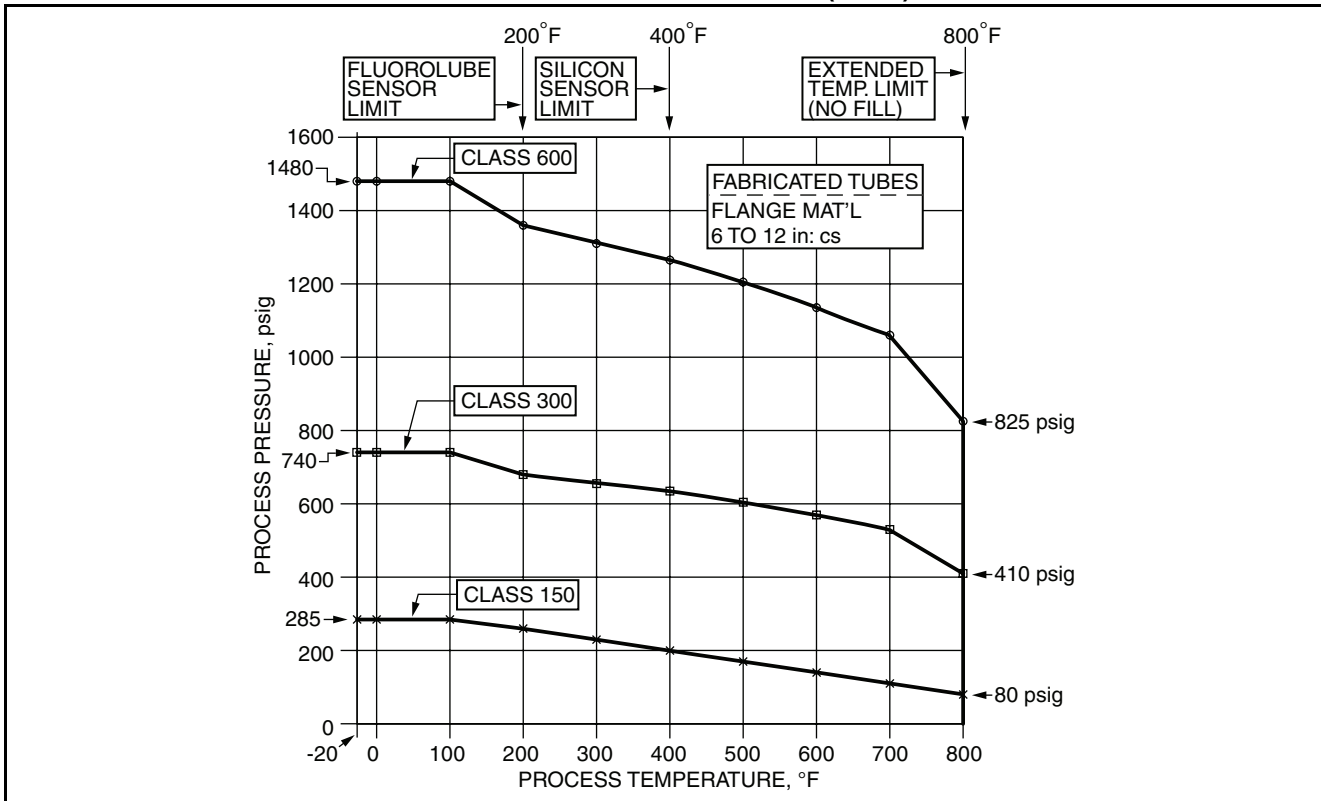

Figure 5. ANSI Flange Ratings; per ASME B16.5; Group 1.1 Materials

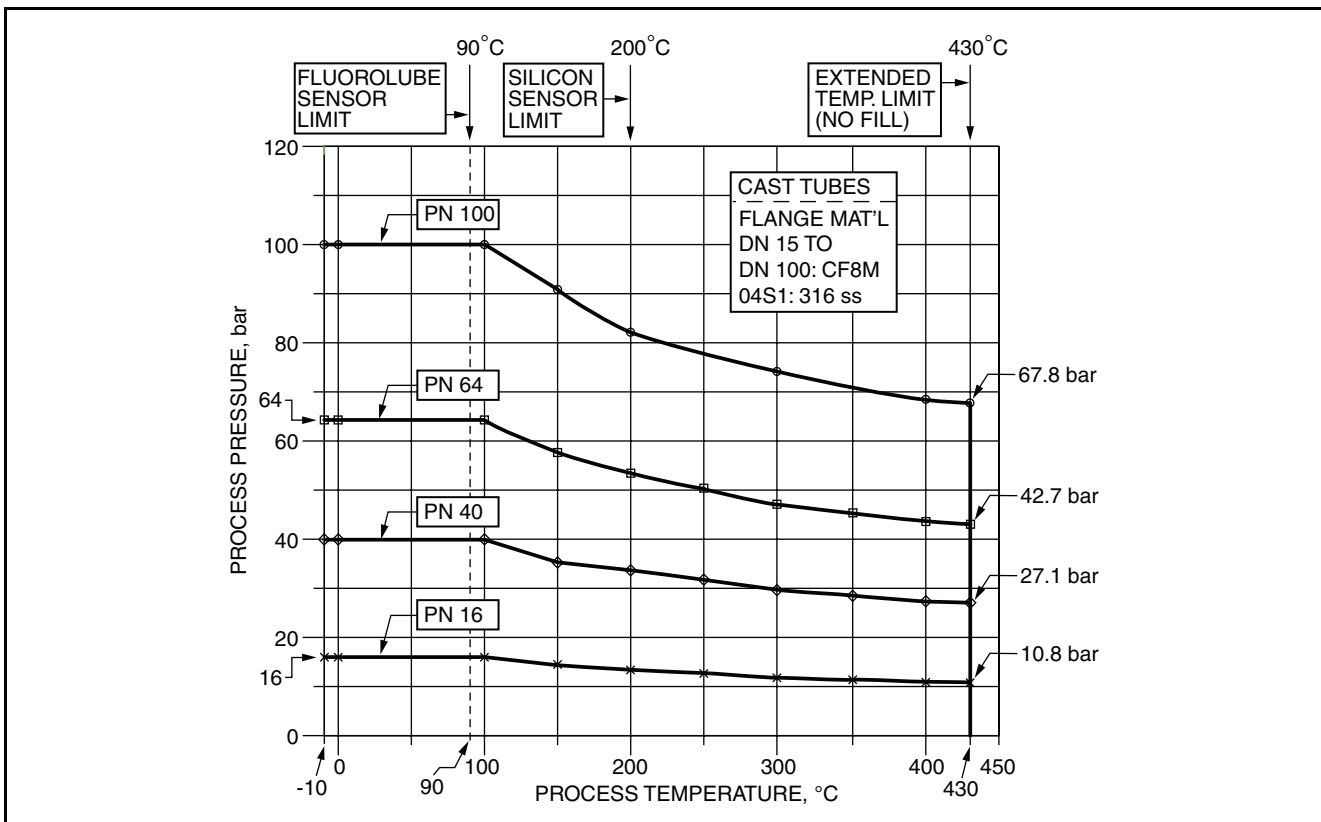

Figure 6. Metric Flange Ratings; Material Group 14E0

FUNCTIONAL SPECIFICATIONS (Cont.)

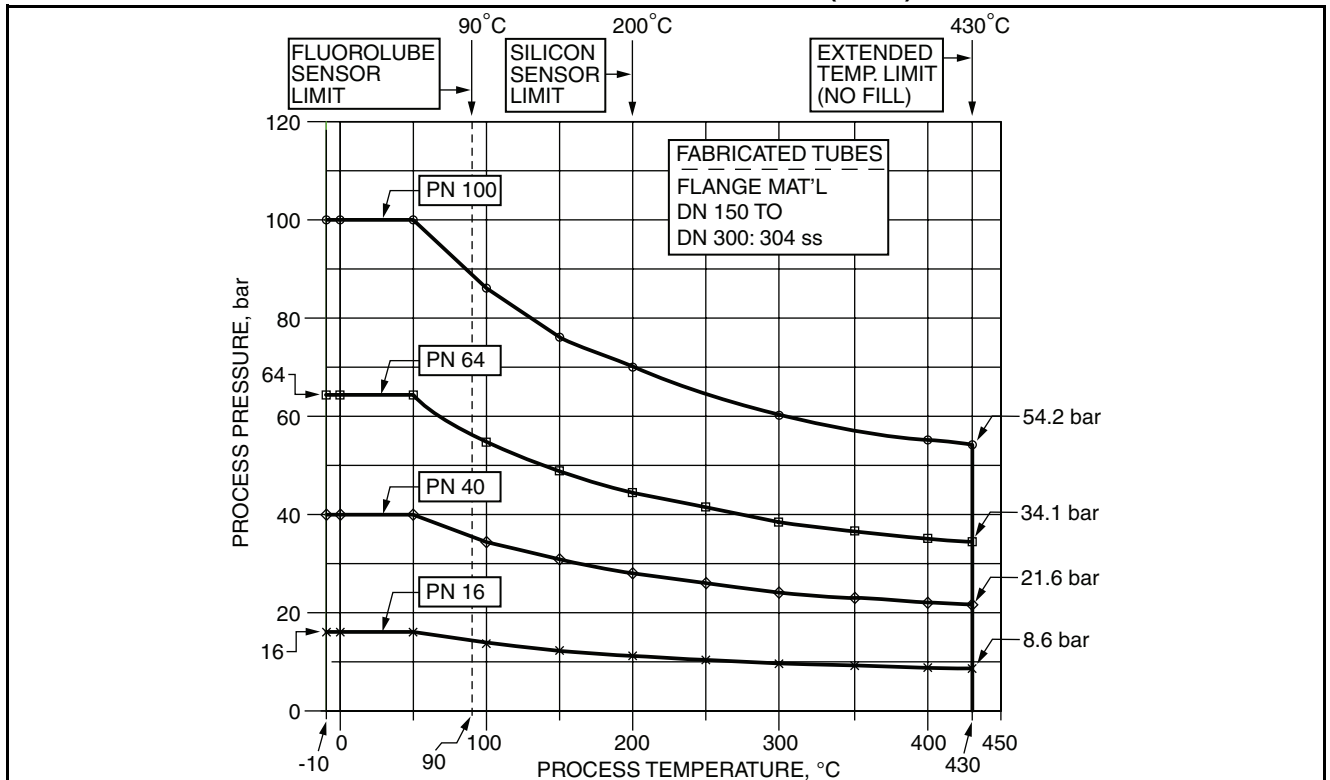

Figure 7. Metric Flange Ratings; Material Group 10E0

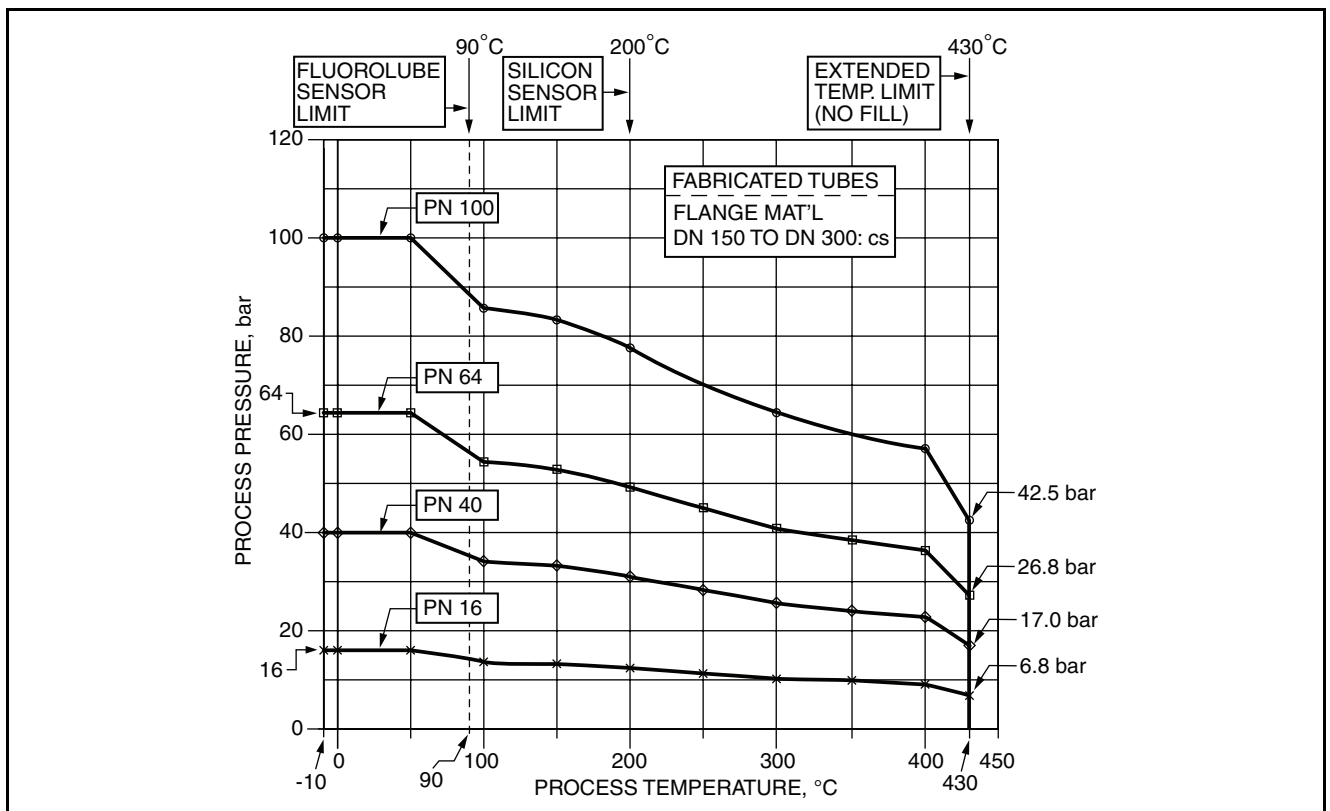

Figure 8. Metric Flange Ratings; Material Group 3E0

FUNCTIONAL SPECIFICATIONS (Cont.)

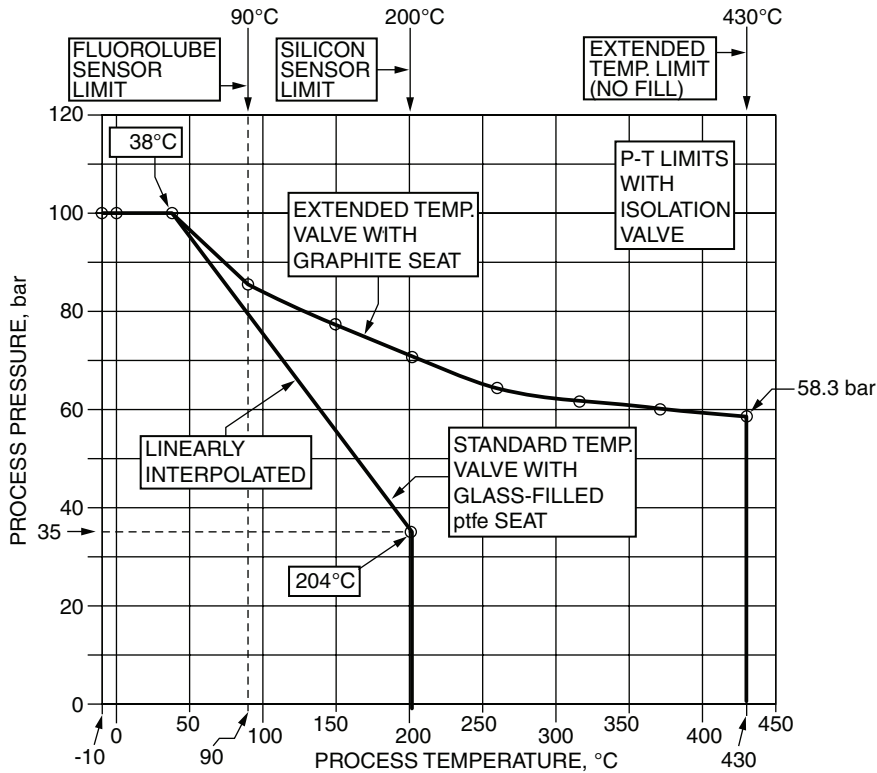
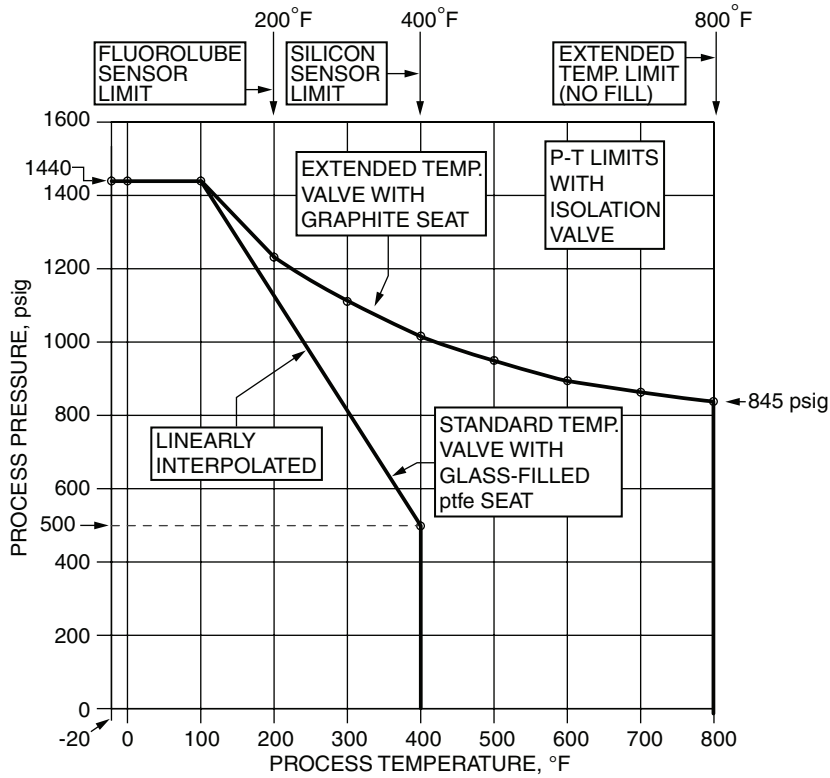

Figure 9. Pressure-Temperature Limits with Isolation Valve; U.S. Customary and Metric Units

PHYSICAL SPECIFICATIONS

Process-Wetted Parts - Model 83F

FLOWMETER BODY, FLANGES, AND SHEDDING BAR (ALSO SEE MODEL CODE)

- 316 ss up to 4 in (DN 100) sizes;
- 304 ss body and shedder, and cs or ss flange, for sizes >4 in (>DN 100).

GASKETS AND FLOW DAM (SENSOR SEALS)

- Standard Temperature Sensor
- ptfе gasket and flow dam
- High Temperature Sensor
- 316 ss gasket; 316 ss/grafoil flow dam
- Hastelloy C gasket; Hastelloy C/grafoil flow dam

Process-Wetted Parts - Model 83W

FLOWMETER BODY AND SHEDDING BAR (ALSO SEE MODEL CODE)

- 316 ss for all sizes; or
- Hastelloy C for 3/4 to 4 in (DN 15 to DN 100) sizes.

GASKETS AND FLOW DAM (SENSOR SEALS)

- Standard Temperature Sensor
- ptfе gasket and flow dam
- High Temperature Sensor
- 316 ss gasket; 316 ss/grafoil flow dam
- Hastelloy C gasket; Hastelloy C/grafoil flow dam

Dual Measurement Manifold - Model 83F Only

CF8M stainless steel; pressure and temperature rating of dual manifold same as flowmeter body.

Flowmeter Mounting

Flowmeter can be located in a pipeline which may run in any direction from the vertical (upward flow) to the horizontal. The electronics housing can also be rotated 270° (in 90° increments) with respect to the body. A vertical pipeline is preferred for batch operations to provide improved full line assurance. See Recommended Mounting Arrangements section.

Electrical Connections

Field wires enter through 1/2 NPT conduit threaded entrances on either side of the electronics housing. Wires terminate under screw terminals and washers on terminal block (see Figure 14) in the field terminal compartment. Unused entrance is plugged to insure moisture and RFI/EMI protection.

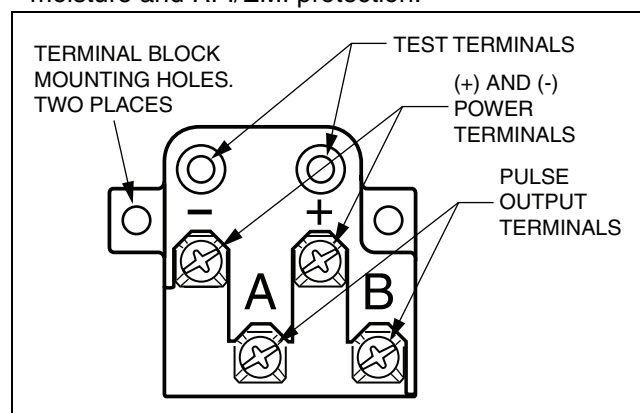

Figure 10. Terminal Block

Electronics Module

Printed wiring assemblies (PWAs) are conformally coated for moisture and dust protection.

Environmental Protection

Electronics housing is dusttight and weatherproof per IEC IP66 and provides the environmental and corrosion resistant protection of NEMA Type 4X.

Isolation Valve (if specified, see Model Code for Selection Options)

VALVE BODY

Grade CF8M stainless steel

VALVE BALL

316 ss

VALVE SEATS

Standard Temperature: Glass-Filled ptfе

Extended Temperature: Graphite

STEM SEAL

The valve stem seal meets the external leakage requirements for fire safety per API Standard 607.

VALVE HANDLE

Use adjustable wrench.

SEAT LEAKAGE

Standard Temperature

Class IV – Less than 5 mL/h per MSS-SPG1.

High Temperature

Class IV per ANSI/FCI-70.2

FLOW VELOCITY LIMITS

See “Flow Velocity Limits” section.

APPLICATIONS

Recommended for use with clean liquids, saturated steam, and all gases.

LIMITATIONS

Not recommended for use with superheated steam without insulation, or liquids with suspended solids.

MOUNTING

See MI 019-202 for installation guidelines.

PRESSURE/TEMPERATURE RATING

Both standard and extended (high) temperature isolation valves have a maximum pressure rating of 1440 psi at 100°F (100 bar at 38°C). The standard temperature valve with ptfе seats is further limited to a maximum pressure of 500 psi at 400°F (35 bar at 204°C). The extended temperature valve has an ANSI Class 600 temperature and pressure rating. See Figure 9.

NACE Certification

The stainless steel material option has been designed, and materials selected, to meet the requirements of NACE (National Association of Corrosion Engineers) Standard MR-01. A NACE compliance certificate is available by selecting the -Q option.

PHYSICAL SPECIFICATIONS (Cont.)

Process Connections

83F FLANGED BODY FLOWMETERS

Refer to the 83F Model Code for the availability of body material, flange material, flange types, and body/flange construction for each line size.

83W WAFER BODY FLOWMETERS

Refer to the 83W Model Code for the availability of body material and mounting/centering system for each line size when mounted between the different flange types. Wafer body flowmeters must be properly aligned to provide optimum accuracy, and alignment spacers are provided to achieve this alignment. Carbon steel bolting kits can also be provided as listed in the Optional Selections and Accessories section.

Dimensions

Refer to Dimensions - Nominal section for general outline data. For more dimensional details, refer to the following Dimensional Prints (DPs).

Model	Configuration	Dimensional Print
83F	Single Measurement	DP 019-150
83F	Dual Measurement	DP 019-151
83W (a)	Single Measurement (a)	DP 019-152

(a) The 83W is not available as Dual Measurement Flowmeter.

Approximate Weight

See Tables 2 to 6.

Table 2. 83F Vortex Flowmeters – Flanged Body: Approximate Weight with ANSI Class 150 Flanges

Nominal Line Size		With Integral Mounted Electronics Housing				With Remote Mounted Electronics Housing					
		Flowmeter Weight(a)				Flowmeter Weight(b)				Electronics Housing Weight(c)	
		Sensor Types D, F, R, & S		Sensor Types C & T		Sensor Types D, F, R, & S		Sensor Types C & T			
in	DN	lb	kg	lb	kg	lb	kg	lb	kg	lb	kg
3/4	DN 15	11.0	5.0	11.7	5.3	9.0	4.1	9.9	4.5	5.0	2.3
1	DN 25	13.2	6.0	13.9	6.3	11.0	5.0	11.9	5.4	5.0	2.3
1 1/2	DN 40	16.0	7.3	16.7	7.6	14.0	6.4	15.0	6.8	5.0	2.3
2	DN 50	20.2	9.2	21.0	9.5	18.0	8.2	19.0	8.6	5.0	2.3
3	DN 80	33.2	15.1	33.9	15.4	29.0	13.2	30.0	13.6	5.0	2.3
4	DN 100	45.0	20.5	45.8	20.8	43.0	19.5	44.0	20.0	5.0	2.3
6	DN 150	72.2	32.8	72.8	33.1	70.0	31.8	71.3	32.3	5.0	2.3
8	DN 200	125.0	56.6	125.4	57.0	121.0	54.9	122.0	55.3	5.0	2.3
10	DN 250	190	86.2	190.0	86.2	185.0	83.9	187.0	84.8	5.0	2.3
12	DN 300	265.0	120.0	265.0	120.0	260.0	118.0	262.0	119.0	5.0	2.3

(a) Weight of complete flowmeter, including integral electronics housing.

(b) Flowmeter Weight is weight of flowtube with sensor plus bonnet plus junction box.

(c) Housing Assembly Weight (for all Sensor Type selections) is weight of electronics housing assembly plus mounting bracket.

Table 3. 83W Vortex Flowmeters – Wafer Body: Approximate Weight

Nominal Line Size		With Integral Mounted Electronics Housing				With Remote Mounted Electronics Housing					
		Flowmeter Weight(a)				Flowmeter Weight(b)				Electronics Housing Weight(c)	
		Sensor Types D, F, R, & S		Sensor Types C & T		Sensor Types D, F, R, & S		Sensor Types C & T			
in	DN	lb	kg	lb	kg	lb	kg	lb	kg	lb	kg
3/4	DN 15	7.0	3.2	7.3	3.3	5.0	2.3	5.5	2.5	5.0	2.3
1	DN 25	8.1	3.7	8.4	3.8	6.0	2.7	6.4	2.9	5.0	2.3
1 1/2	DN 40	9.0	4.1	9.2	4.2	7.0	3.2	7.5	3.4	5.0	2.3
2	DN 50	12.0	5.4	12.3	5.6	10.0	4.5	10.3	4.7	5.0	2.3
3	DN 80	17.2	7.8	17.4	7.9	15.0	6.8	15.4	7.0	5.0	2.3
4	DN 100	25.0	11.3	25.3	11.5	23.0	10.4	23.5	10.7	5.0	2.3
6	DN 150	37.0	16.8	37.2	16.9	35.0	16.0	35.6	16.2	5.0	2.3
8	DN 200	61.1	27.7	61.3	27.8	59.0	26.8	59.4	27.0	5.0	2.3

(a) Weight of complete flowmeter, including electronics housing.

(b) Flowmeter Weight is weight of flowtube with sensor plus bonnet plus junction box.

(c) Housing Assembly Weight (for all Sensor Type selections) is weight of electronics housing assembly plus mounting bracket.

PHYSICAL SPECIFICATIONS (Cont.)

Table 4. Additional Weight for Single Measurement Flowmeter with Isolation Valve
(Add Weight in this table to Tables 3 and 4 Weights as Applicable)

Nominal Line Size(a)		With Integral Mounted Electronics Housing				With Remote Mounted Electronics Housing			
		Added Weight with Sensor Types				Added Weight with Sensor Types			
		D, F, R, & S		C & T		D, F, R, & S		C & T	
in	DN	lb	kg	lb	kg	lb	kg	lb	kg
All	All	2.1	1.0	2.1	1.0	2.1	1.0	2.1	1.0

(a) Sizes 10 and 12 in (DN 250 and DN 300) not available with wafer body flowmeter.

Table 5. Additional Weight for Dual Measurement Flowmeter without Isolation Valves
(Add Weight in this table to Table 3 Weight)

Nominal Line Size(a)		With Integral Mounted Electronics Housing				With Remote Mounted Electronics Housing			
		Added Weight with Sensor Types(b)				Added Weight with Sensor Types(c)			
		D, F, R, & S		C & T		D, F, R, & S		C & T	
in	DN	lb	kg	lb	kg	lb	kg	lb	kg
All	All	11.9	5.4	12.6	5.7	7.2	3.3	8.8	4.0

(a) Dual Measurement Flowmeters are only available with Flanged Body Flowtubes.

(b) Added weight includes dual manifold without valves, one sensor, a bonnet, an electronics housing, and a support bracket.

(c) Added weight includes dual manifold without valves, one sensor, a bonnet, a junction box assembly, and a support bracket.

Table 6. Additional Weight for Dual Measurement Flowmeter with Isolation Valves
(Add Weight in this table to Table 3 Weight)

Nominal Line Size(a)		With Integral Mounted Electronics Housing				With Remote Mounted Electronics Housing			
		Added Weight with Sensor Types(b)				Added Weight with Sensor Types(c)			
		D, F, R, & S		C & T		D, F, R, & S		C & T	
in	DN	lb	kg	lb	kg	lb	kg	lb	kg
All	All	15.0	6.8	15.7	7.1	10.3	4.7	11.8	5.4

(a) Dual Measurement Flowmeters are only available with Flanged Body Flowtubes.

(b) Added weight includes dual manifold with valves, one sensor, a bonnet, an electronics housing, and a support bracket.

(c) Added weight includes dual manifold with valves, one sensor, a bonnet, a junction box assembly, and a support bracket.

PRODUCT SAFETY SPECIFICATIONS

Pressure Safety

Designed to withstand ANSI and metric pressure-temperature ratings as shown in Figures 3 to 8. Note, for Wafer Body Flowmeters, the flowtube face outside diameter is designed to center between ANSI Class 150 flanges. For other flange ratings, centering spacers are provided.

Personnel and Electrical Fire Safety

This device is designed to be a minimum fire hazard by using low energy power and adequate insulation and separation of electrical circuits. The required standards of worldwide testing agencies such as FM, ATEX, CSA, IEC and OSHA have been fulfilled.

Electrical Safety Specifications

Testing Laboratory, Types of Protection and Area Classification	Application Conditions	Electrical Safety Design Code
ATEX, II 2 G, EEx ib IIC	Temperature Class T4 at 0.8 W, at -20 to +80°C. Temperature Class T5 at 0.7 W, at -20 to +40°C. Temperature Class T6 at 0.5 W, at -20 to +40°C.	E
ATEX, II 3 G, EEx nL IIC	Temperature Class T4, -20 to +70°C Temperature Class T5, -20 to +70°C Temperature Class T6, -20 to +40°C	N
CSA intrinsically safe for Class I, Division 1, Groups A, B, C, and D; Class II, Division 1, Groups E, F, G; and Class III, Division 1.	Temperature Class T3C at 85°C and T4A at 40°C.	A
CSA explosionproof for Class I, Division 1, Groups C and D; dust-ignitionproof for Class II, Division 1, Groups E, F, G; and Class III, Division 1.	Maximum ambient = 85°C.	
Suitable for Class I, Division 2, Groups A, B, C, D; Class II, Division 2, Groups F, G; and Class III, Division 2.		
FM intrinsically safe for Class I, Division 1, Groups A, B, C, D; Class II, Division 1, Groups E, F, G; and Class III, Division 1.	Temperature Class T3C, Ta = 85°C; and T4A, Ta = 40°C.	
FM explosionproof for Class I, Division 1, Groups C and D; dust-ignitionproof for Class II, Division 1, Groups E, F, G; and Class III, Division 1.	Temperature Class T5, Ta = 85°C.	
FM nonincendive for Class I, Division 2, Groups A, B, C, D; suitable for Class II, Division 2, Groups E, F, G; and Class III, Division 2.	Temperature Class T5, Ta = 85°C.	

NOTE

These I/A Series Intelligent Vortex Flowmeters have been designed to meet the electrical classifications listed in the table above. Contact Invensys Foxboro for more approval and certification information.

RECOMMENDED MOUNTING ARRANGEMENTS

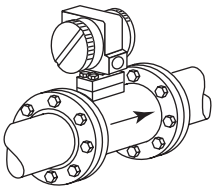
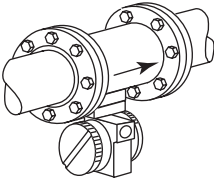
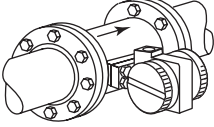
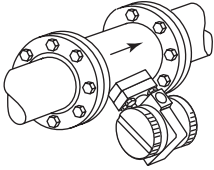
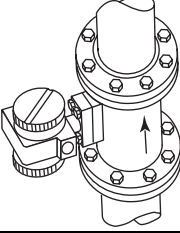
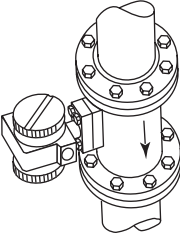
Flowmeter Mounting Arrangement Model 83F Single Measurement Flowmeter Shown (Dual Measurement Flowmeters follow same arrangements)		Flowmeter for Use With:			
		Liquid	Gas	Saturated Steam	Superheated Steam
	Housing Above Pipe; Isolation Valve and Dual Measurement Flowmeter NOT Used.	Yes (1)	Yes	No	Yes (2)
	Housing Above Pipe; Isolation Valve and Dual Measurement Flowmeter CAN be Used.	No (5)	Yes	No	Yes (2)
	Housing Below Pipe.	Yes (3) (4) (6)	Yes (4)	Yes	Yes (2)
	Housing to Side of Pipe.	Yes	Yes	No	Yes (2)
	Housing to Side and Below Pipe.	Yes (6)	Yes	No	Yes (2)
	Vertical Pipe, Flow upward.	Yes	Yes	No	Yes (2)
	Vertical Pipe, Flow Downward.	Yes (7)	Yes	No	Yes (2)

- (1) Possibility of temporary start-up error due to trapped air.
- (2) Requires adequate insulation.
- (3) Best choice when errors due to start-up cannot be tolerated.
- (4) Recommended only for clean fluids.

- (5) Not recommended for liquids with isolation valve.
- (6) Preferred for liquids with isolation valve.
- (7) Not preferred; must maintain full pipe with no voids in fluid.

OPTIONAL SELECTIONS AND ACCESSORIES

Options -B, -D, -E, -G; Cable Assembly to Remote Electronics Housing

When selecting Code R for a Remote Mounted Electronics Housing, an optional cable length selection must also be made. Invensys Foxboro offers four cable lengths as follows:

Optional Suffix	Cable Length
-B	20 ft (6 m)
-D	30 ft (9 m)
-E	40 ft (12 m)
-G	50 ft (15 m)

Option -C; Calibration Cable

A calibration cable that can be plugged into the amplifier is available to connect to a frequency generator to check the frequency-to-analog calibration of amplifier. Available by selecting Optional Suffix -C.

Option -F, -V, -X; Welding Certificates - with Flanged Body Flowtubes only

Three certificates are available. Option -F certifies that the fabrication of 6 to 12 in (150 to 300 mm) flowtubes by welders is to ASME Boiler Code, Section IX. Option -V provides radiographic examination (X-ray) certification of circumferential welds (not available with ANSI Class 150 or Metric PN16 flanges). And Option -X certifies that welding is per ASME Boiler Code and Radiographic Examination (except as noted for Option -F).

Option -H; Oxygen or Chlorine Service

Wetted parts are cleaned for oxygen or chlorine service in compliance with Compressed Gas Association's CGA-4.1 and ASTM G93. Cleaning is not available when an isolation valve, or dual measurement or extended temperature meters are selected. Select Optional Suffix -H.

Option -J; Gold Plated Sensor

Ideally suited for H₂ or extremely corrosive processes. Specify Optional Suffix -J.

Options -L, -M, -Q; Certificates of Conformance and Compliance

Three material certificates are offered. Optional Suffix -L provides a certificate of compliance to Invensys Foxboro specifications. The Invensys Foxboro quality system conforms to ISO 9001. Suffix -M is a certification of material for process wetted metal (conforms to BS EN 10204-3.1). And, Suffix -Q certifies that stainless steel materials meet NACE Standard MR-01.

Option -N; Certified Calibration Certificate

A calibration and test certificate are provided standard with each flowmeter. A certified flow calibrated K-factor and pressure test certificate is available by selecting Optional Suffix -N.

Option -P; Hawke-Type Cable Gland

Brass cable gland with 1/2 NPT external thread. Provides support for field cable. Available with Electrical Safety Codes E and Z only. Used with Electrical Housing Codes T and R only (1/2 NPT). Select Option -P.

Options -R and -S; PG11 and PG13.5 Cable Glands

Cable glands with 1/2 NPT external thread provide strain relieved support for field cable. The PG11 has an I.D. of 0.50 in (12.7 mm) and the PG13.5 has an I.D. of 0.53 in (13.5 mm). They are not for use with units having explosionproof or flameproof certifications. Available with Electrical Housing Codes T and R only (1/2 NPT). Select Option -R for the PG11 and Option -S for the PG13.5.

AS Code MTS; Stainless Steel Customer Tag

This optional accessory adds a 40 x 90 mm (1.5 x 3.5 in) stainless steel tag for customer data that does not fit on the standard stainless steel data plate. It is fastened to housing with stainless steel wire. There can be a maximum of 10 lines of data with 40 characters and spaces per line. This tag will also show the K-factor specific to customer application (information with flowing conditions being submitted to Invensys Foxboro with the purchase order). Specify AS Code MTS.

Bolting Kits – With Wafer Body Flowtubes Only

Sets of carbon steel studs and nuts which conform to line size, and ANSI or metric size and rating, are offered in 3/4 to 4 in line sizes for ANSI flanges, and 50 to 100 mm line sizes for metric flanges. See tables below to select the kit and part number required.

ANSI Flange Bolting Kits - Part Numbers

Size	Cl. 150	Cl. 300	Cl. 600
3/4 in	D0148ZF	D0148ZJ	D0148ZJ
1 in	D0148ZF	D0148ZJ	D0148ZJ
1 1/2 in	D0148ZF	D0148ZK	D0148ZS
2 in	A2044HB	A2044HB (a)	A2044HC (a)
3 in	A2044HC	A2044HD	A2044HD
4 in	A2044HC (a)	A2044HD	A2044HE

(a) Two kits required.

Metric Flange Bolting Kits - Part Numbers

Size	PN 16	PN 40	PN 64	PN 100
50 mm	N/A	D0148ZU	N/A	N/A
80mm	N/A	D0148ZZ (a)	N/A	N/A
100 mm	L0114NT	L0114NT	N/A	N/A

(a) Two kits required.

MODEL CODES

Model 83F Vortex Flowmeters – Flanged Body

Description

83F = Vortex Flowmeter – Flanged Body

Electronics Type

-A = 4 to 20 mA Analog and Pulse Electronics

Nominal Line Size

3Q = 3/4 in (DN 15) Line Size
 01 = 1 in (DN 25) Line Size
 1H = 1 1/2 in (DN 40) Line Size
 02 = 2 in (DN 50) Line Size
 03 = 3 in (DN 80) Line Size
 04 = 4 in (DN 100) Line Size
 06 = 6 in (DN 150) Line Size
 08 = 8 in (DN 200) Line Size
 10 = 10 in (DN 250) Line Size
 12 = 12 in (DN 300) Line Size

Body and Flange Material

S = Sizes 3Q to 04: Cast Body/Flange and Shedder (except Code 04S1); CF8M Material
 Size 04S1: Fabricated from 316 ss Tubing and Flanges
 Sizes 06 to 12: Body Fabricated from 304 ss Tubing with 304 ss Flanges
 K = Sizes 06 to 12: Body Fabricated from 304 ss Tubing with Carbon Steel (A105) Flanges

End Connections and Flange Rating

<u>Description</u>	<u>Used with Line Sizes</u>
1 = ANSI Class 150 Flange, RF, per ASME B16.5	All line sizes
2 = ANSI Class 300 Flange, RF, per ASME B16.5	All line sizes
3 = ANSI Class 600 Flange, RF, per ASME B16.5	Sizes 3Q through 08 only
4 = Metric PN 16 Flange, RF, Finish Form D, per ASME B16.5	Sizes 06 through 08 only
5 = Metric PN 40 Flange, RF, Finish Form D, per DIN 2501	All line sizes
6 = Metric PN 64 Flange, RF, Finish Form E, per DIN 2501	Sizes 02 through 12 only
7 = Metric PN 100 Flange, RF, Finish Form E, per DIN 2501	Sizes 3Q through 08 only
8 = Metric PN 40 Flange, RF, Finish Form C, per DIN 2501	Sizes 3Q through 04 only
A = Metric PN 40 Flange, RF, Finish Form N, per DIN 2501	All line sizes
B = Metric PN 64 Flange, RF, Finish Form N, per DIN 2501	Sizes 02 through 12 only
C = Metric PN 100 Flange, RF, Finish Form N, per DIN 2501	Sizes 3Q through 08 only
D = Metric PN 16 Flange, RF, Finish Type B1, per EN 1092-1	Sizes 06 through 08 only (e)
F = Metric PN 40 Flange, RF, Finish Type B1, per EN 1092-1	All line sizes (e)
H = Metric PN 100 Flange, RF, Finish Type B1, per EN 1092-1	All line sizes (e)

Single or Dual Measurement and Isolation Valve

S = Single Measurement; No Isolation Valve
 D = Dual Measurement; Manifold with No Isolation Valve
 K = Single Measurement; Manifold with one Isolation Valve; CF8M Stainless Steel
 L = Dual Measurement; Manifold with two Isolation Valves; CF8M Stainless Steel

Sensor Fill, Temperature Range, and Material

Standard Temperature Range (with Fill Fluid)

D = Fluorolube Fill, 0 to 200 °F (–20 to +90 °C) Hastelloy Type CW2M
 F = Fluorolube Fill, 0 to 200 °F (–20 to +90 °C) Stainless Steel Type CF3M
 R = Silicone Fill, 0 to 400 °F (–20 to +200 °C) Hastelloy Type CW2M
 S = Silicone Fill, 0 to 400 °F (–20 to +200 °C) Stainless Steel Type CF3M

High Temperature Range (No Fill Fluid) (d)

C = Unfilled, 400 to 800 °F (200 to 430 °C) Hastelloy Type CW2M
 T = Unfilled, 400 to 800 °F (200 to 430 °C) Stainless Steel Type CF3M

Model 83F Code continued on next page

MODEL CODES (Cont.)**Model 83F Vortex Flowmeters - Flanged Body (Cont.)****Electronics Housing Mounting, Material, and Conduit Connections**

- T = Mounted to Flowtube; Aluminum Housing; 1/2 NPT Conduit Connections (a)
- R = Remote Mounted; Aluminum Housing; 1/2 NPT Conduit Connections (a)
Also must select Cable Length in Options Section.

Output Indicator

- N = No Output Indicator (Blind Unit)
- A = Analog Output Indicator, 4 to 20 mA, 0 to 100% Scale
- B = Analog Output Indicator, Ten Equally Spaced Division
- E = Pulse Output Indicator, 0 to 100% Scale
- D = Pulse Output Indicator, Ten Equally Spaced Divisions

Electrical Safety (See Electrical Safety Specifications Section for further details)

- A = CSA intrinsically safe, Division 1.
CSA explosionproof, Division 1.
CSA suitable for Class I, II, and III, Division 2.
FM intrinsically safe, Division 1.
FM explosionproof, Division 1.
FM nonincendive, Class I, II, and III, Division 2.
- E = ATEX intrinsically safe, II 2 G, EEx ib IIC.
- N = ATEX protection n, II 3 G, EEx nL IIC
- Z = No Approval/Certification Required

Optional Selections**Cable Length Selection for Remote Electronics Housing**

- B = 20 ft (6 m) Cable to Connect to Remote Electronics Housing
- D = 30 ft (9 m) Cable to Connect to Remote Electronics Housing
- E = 40 ft (12 m) Cable to Connect to Remote Electronics Housing
- G = 50 ft (15 m) Cable to Connect to Remote Electronics Housing

Calibration Cable

- C = Cable used to Check Amplifier Calibration

Cleaning for Oxygen or Chlorine Service

- H = Cleaning of Process Wetted Parts for Oxygen/Chlorine Service per CGA G-4.1 and ASTM G93 (Not with Measurement/Isolation Valve Codes "D", "K", and "L", Extended Temperature Sensor Codes "C" and "T", or Size Codes "10" and "12")

Sensor Plating

- J = Gold Plated Sensor

Invensys Foxboro Certificates of Compliance/Conformance

- L = Standard Certificate of Compliance (ISO 9001)
- M = Foxboro Material Certification of Process Wetted Metal (Conforms to BS EN 10204.3.1)
- Q = Process Wetted Parts Conform to NACE MR-01

Invensys Foxboro Certified Calibration Certificate

- N = Foxboro Calibration and Pressure Test Certification

Cable Connections - with Electrical Housing Codes T and R (1/2 NPT)

- P = Hawke-Type Cable Gland (with Electrical Safety Codes E and Z only)
- R = PG11 Trumpet Gland (not with flameproof/explosionproof certifications)
- S = PG13.5 Trumpet Gland (not with flameproof/explosionproof certifications)

Welding Certificate (Size Codes 06 through 12 only) (b)(c)

- F = Welding Certified to the ASME Boiler Code
- V = Radiographic Examination of Flange Welds (except ANSI 150 and Metric PN 16)
- X = Welding Certified to the ASME Boiler Code; includes Radiographic Examination

Examples: 83F-D02S1SDTNA-X; 83F-T06K7DCRJE-GQNX

- (a) ATEX intrinsically safe certifications not available with 1/2 NPT openings.
- (b) Select one certificate only. Note that Certificate -X includes both -F and -V certifications.
- (c) Not available when Size Code 06 or 08 is combined with End Connection Code 1 or 4.
- (d) Application ALERT: for Extended Temperature Range sensors used in hazardous or volatile gas applications, there is the potential of fugitive emissions to occur through the sensor vented restrictor if the sensor diaphragm were to fail.
- (e) Contact Invensys Foxboro if metric flanges per EN 1092-1 are selected.

MODEL CODES (Cont.)**Model 83W Vortex Flowmeters – Wafer Body****Description**

83W = Vortex Flowmeter – Wafer Body

Electronics Type

-A = 4 to 20 mA Analog and Pulse Electronics

Nominal Line Size

3Q = 3/4 in (DN 15) Line Size
 01 = 1 in (DN 25) Line Size
 1H = 1 1/2 in (DN 40) Line Size
 02 = 2 in (DN 50) Line Size
 03 = 3 in (DN 80) Line Size
 04 = 4 in (DN 100) Line Size
 06 = 6 in (DN 150) Line Size
 08 = 8 in (DN 200) Line Size

Body Material

S = ASTM A351-CF8M (316 ss) Cast Body and Shedder
 H = ASTM A494-CW2M (Hastelloy C) Cast Body and Shedder; with Size Codes 3Q to 04 only.

Mounting and Centering System

1 = Centering for the following Flanges:
 ANSI Class 150 and ANSI Class 300
 ANSI Class 600 with Sizes 3Q to 04 only
 Metric PN 16 with Sizes 01 to 03 only
 Metric PN 40 with Sizes 01 to 03, and 06, and 08
 Metric PN 64 and Metric PN 100

Isolation Valve

S = No Isolation Valve
 K = Isolation Valve, Type CF8M Stainless Steel

Sensor Fill, Temperature Range, and Material***Standard Temperature Range (with Fill Fluid)***

D = Fluorolube Fill, 0 to 200 °F (–20 to +90 °C) Hastelloy Type CW2M
 F = Fluorolube Fill, 0 to 200 °F (–20 to +90 °C) Stainless Steel Type CF3M
 R = Silicone Fill, 0 to 400 °F (–20 to +200 °C) Hastelloy Type CW2M
 S = Silicone Fill, 0 to 400 °F (–20 to +200 °C) Stainless Steel Type CF3M

High Temperature Range (No Fill Fluid) (b)

C = Unfilled, 400 to 800 °F (200 to 430 °C) Hastelloy Type CW2M
 T = Unfilled, 400 to 800 °F (200 to 430 °C) Stainless Steel Type CF3M

Mounting for Electronics Housing

T = Mounted to Flowtube; Aluminum Housing; 1/2 NPT Conduit Connections (a)
 R = Remote Mounted; Aluminum Housing; 1/2 NPT Conduit Connections (a)
 Also must select Cable Length in Options Section.

Model 83W Code continued on next page

MODEL CODES (Cont.)
Model 83W Vortex Flowmeters - Wafer Body (Cont.)**Local Digital Display/Configurator**

- N = No Output Indicator (Blind Unit)
- A = Analog Output Indicator, 4 to 20 mA, 0 to 100% Scale
- B = Analog Output Indicator, Ten Equally Spaced Divisions
- E = Pulse Output Indicator, 0 to 100% Scale
- D = Pulse Output Indicator, Ten Equally Spaced Divisions

Electrical Safety (See Electrical Safety Specifications Section for further details)

- A = CSA intrinsically safe, Division 1.
CSA explosionproof, Division 1.
CSA suitable for Class I, II, and III, Division 2.
FM intrinsically safe, Division 1.
FM explosionproof, Division 1.
FM nonincendive, Class I, II, and III, Division 2.
- E = ATEX intrinsically safe, II 2 G, EEx ib IIC.
- N = ATEX protection n, II 3 G, EEx nL IIC
- Z = No Approval/Certification Required

Optional Selections***Cable Length Selection for Remote Electronics Housing***

- B = 20 ft (6 m) Cable to Connect to Remote Electronics Housing
- D = 30 ft (9 m) Cable to Connect to Remote Electronics Housing
- E = 40 ft (12 m) Cable to Connect to Remote Electronics Housing
- G = 50 ft (15 m) Cable to Connect to Remote Electronics Housing

Calibration Cable

- C = Cable used to Check Amplifier Calibration

Cleaning for Oxygen or Chlorine Service

- H = Cleaning Process Wetted Parts per CGA G-4.1 and ASTM G93
(Not available with Isolation Valve, Code K or Extended Temperature Sensor Codes "C" and "T")

Sensor Plating

- J = Gold Plated Sensor

Invensys Foxboro Certificates of Compliance/Conformance

- L = Standard Certificate of Compliance
- M = Invensys Foxboro Material Certification of Process Wetted Metal
(Conforms to BS EN 10204-3.1)
- Q = Process Wetted Parts Conform to NACE MR-01

Invensys Foxboro Calibration Certificate

- N = Invensys Foxboro Calibration and Pressure Test Certification

Cable Connections - with Electrical Housing Codes T and R (1/2 NPT)

- P = Hawke Cable Gland
- R = PG11 Trumpet Gland

Examples: 83W-D02S1KFTJA-Q; 83W-T06S4SDRJA-GNP

- (a) ATEX intrinsically safe certification not available with 1/2 NPT openings.
- (b) Application ALERT: for Extended Temperature Range sensors used in hazardous or volatile gas applications, there is the potential of fugitive emissions to occur through the sensor vented restrictor if the sensor diaphragm were to fail.

DIMENSIONS - NOMINAL

**mm
in**

83F AND 83W FLANGED AND WAFER BODY FLOWTUBES; INTEGRAL MOUNT; SINGLE MEASUREMENT

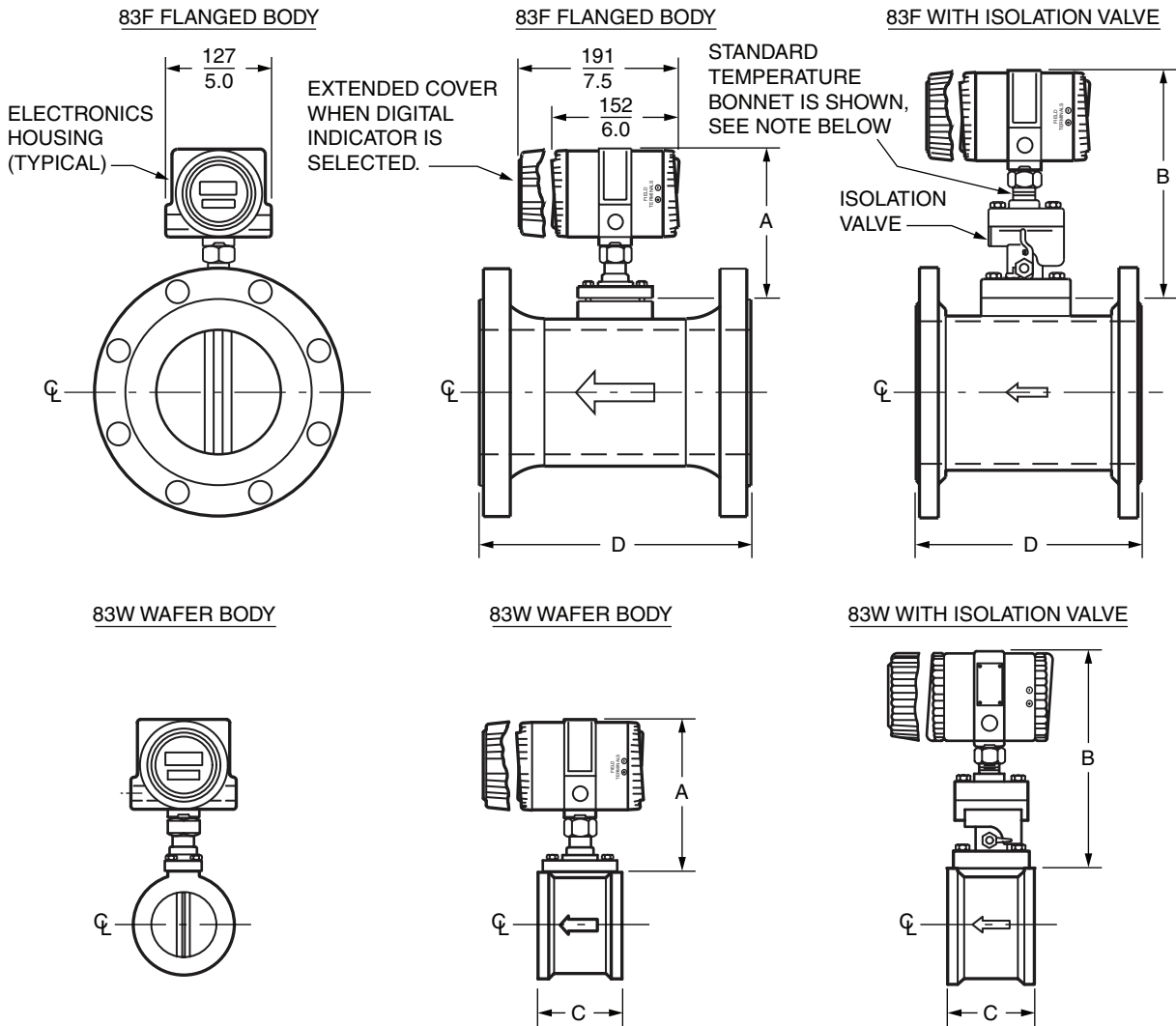

Dimension	Dimensions - Nominal Line Size Code (a)									
	3Q	01	1H	02	03	04	06	08	10 (b)	12 (b)
A	188 7.4	188 7.4	188 7.4	188 7.4	188 7.4	188 7.4	188 7.4	188 7.4	188 7.4	188 7.4
B	257 10.1	257 10.1	257 10.1	257 10.1	257 10.1	257 10.1	257 10.1	257 10.1	257 10.1	257 10.1
C	79.5 3.13	79.5 3.13	79.5 3.13	79.5 3.13	95.3 3.75	121 4.75	178 7.0	229 9.0	N/A	N/A
D	Dimension D varies with flange type, rating, and size. See Table 7 further in document for dimensions.									

(a) Refer to Model Code section for nominal line sizes in DN or inches.

(b) Size Codes 10 and 12 are not available with wafer body flowtubes.

NOTE:

1. Dimensions A and B are shown with the standard temperature bonnet. With extended temperature applications; add 2.6 in (66 mm) to Dimensions A and B because of the longer bonnet.
2. For additional dimensions, also refer to DP 019-150 for the Model 83F, and DP 019-152 for the Model 83W.

DIMENSIONS - NOMINAL (Cont.)

**mm
in**

83F FLANGED FLOWTUBE; INTEGRAL MOUNT; DUAL MEASUREMENT

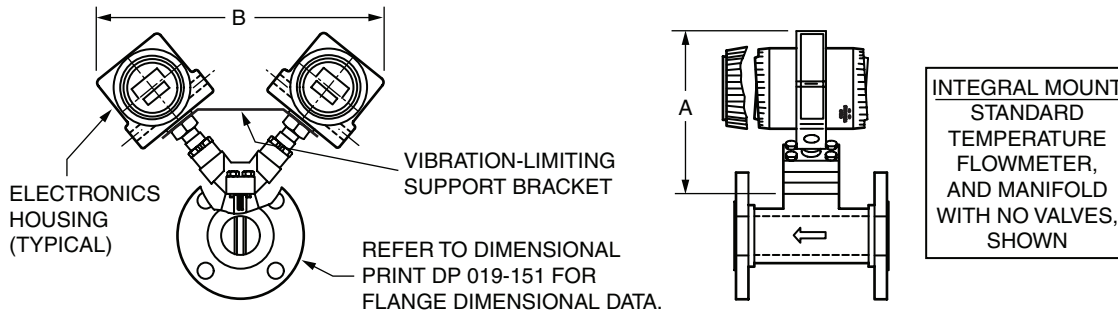

Integral Mount Dimensions

Dimension	Standard Temperature Flowmeter		Extended Temperature Flowmeter	
	No Isolation Valves	With Isolation Valves	No Isolation Vales	With Isolation Valves
A	$\frac{198}{7.8}$	$\frac{216}{8.5}$	$\frac{262}{10.3}$	$\frac{274}{10.8}$
B	$\frac{394}{15.5}$	$\frac{432}{17.0}$	$\frac{495}{19.5}$	$\frac{521}{20.5}$

83F FLANGED FLOWTUBE; REMOTE MOUNT; DUAL MEASUREMENT

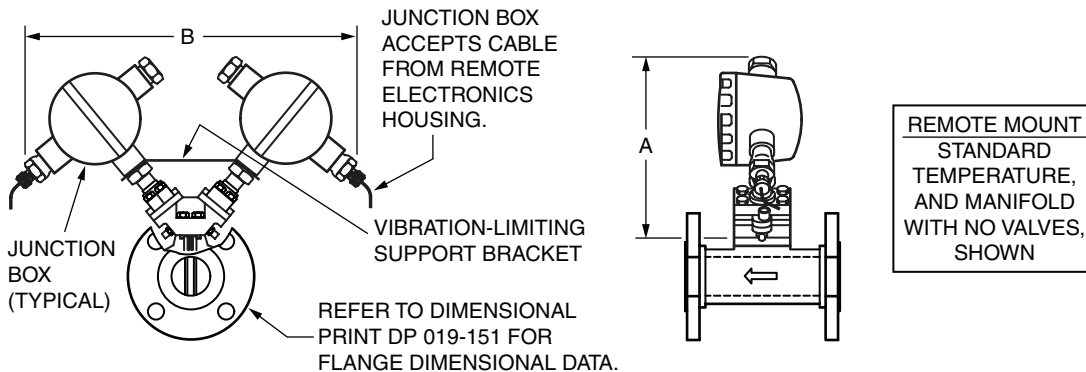

Remote Mount Dimensions

Dimension	Standard Temperature Flowmeter		Extended Temperature Flowmeter	
	No Isolation Valves	With Isolation Valves	No Isolation Vales	With Isolation Valves
A	$\frac{211}{8.3}$	$\frac{236}{9.3}$	$\frac{265}{10.5}$	$\frac{292}{11.5}$
B	$\frac{401}{15.8}$	$\frac{457}{18.0}$	$\frac{503}{19.8}$	$\frac{533}{21.0}$

NOTE:

Also refer to DP 019-151 for further dimensions.

DIMENSIONS - NOMINAL (Cont.)

mm
in

83F AND 83W FLANGED AND WAFER BODY FLOWMETERS WITH REMOTE MOUNTED ELECTRONICS

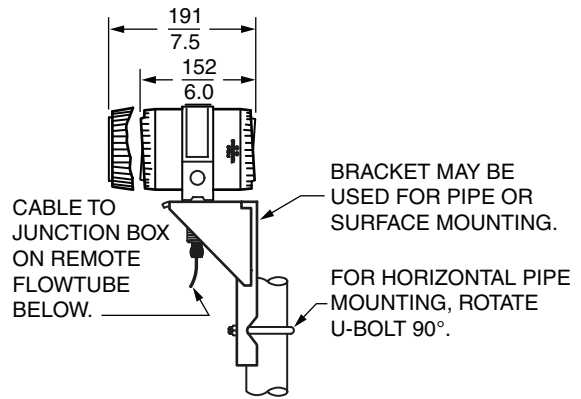
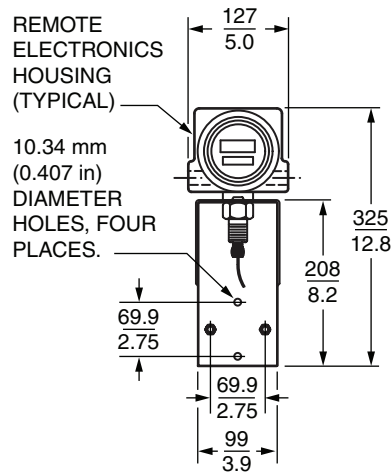

83W WAFER BODY

83W WITH ISOLATION VALVE

83F FLANGED BODY

83F WITH ISOLATION VALVE

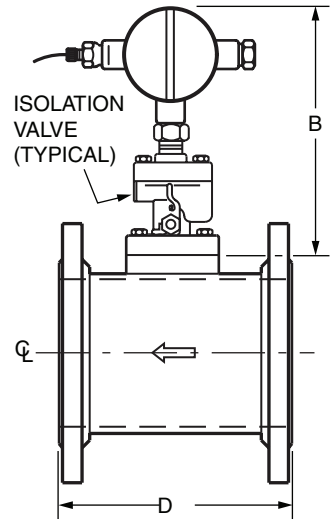
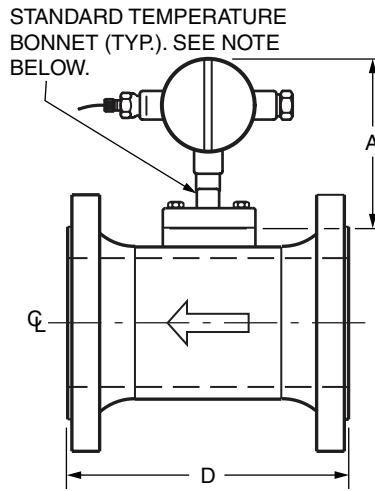
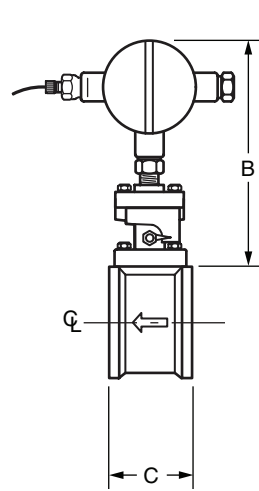
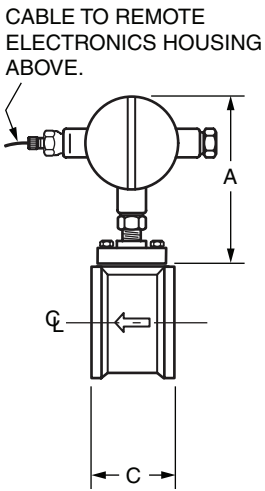

Dimension	Dimensions - Nominal Line Size Code (a)									
	3Q	01	1H	02	03	04	06	08	10 (b)	12 (b)
A	188 7.4	188 7.4	188 7.4	188 7.4	188 7.4	188 7.4	188 7.4	188 7.4	188 7.4	188 7.4
B	257 10.1	257 10.1	257 10.1	257 10.1	257 10.1	257 10.1	257 10.1	257 10.1	257 10.1	257 10.1
C	79.5 3.13	79.5 3.13	79.5 3.13	79.5 3.13	95.3 3.75	121 4.75	178 7.0	229 9.0	N/A	N/A
D	Dimension D varies with flange type, rating, and size. See Table 7 further in document for dimensions.									

(a) Refer to Model Code section for nominal line sizes in DN or inches.

(b) Size Codes 10 and 12 are not available with wafer body flowtubes.

NOTE:

1. Dimensions A and B are shown with the standard temperature bonnet. With extended temperature applications; add 2.6 in (66 mm) to Dimensions A and B because of the longer bonnet.
2. For additional dimensions, also refer to DP 019-150 for the Model 83F, and DP 019-152 for the Model 83W.

DIMENSIONS - NOMINAL (Cont.)

Table 7.
Dimension "D" (Face-to-Face) for Model 83F Flanged Body Flowtubes

ANSI Flanges			Metric Flanges		
Line Size	Flange Rating	Dimension "D" (a)	Line Size	Flange Rating	Dimension "D" (b)
3/4 in	Class 150	6.00 in	DN 15	PN 40	152 mm
	Class 300	6.00 in		PN 100	152 mm
	Class 600	6.50 in	DN 25	PN 40	166 mm
1 in	Class 150	6.50 in		PN 100	178 mm
	Class 300	6.50 in	DN 40	PN 40	179 mm
	Class 600	7.00 in		PN 100	196 mm
1 1/2 in	Class 150	7.25 in	DN 50	PN 40 (c)	195 mm
	Class 300	7.25 in		PN 64	205 mm
	Class 600	7.80 in		PN 100	205 mm
2 in	Class 150	7.75 in	DN 80	PN 40	220 mm
	Class 300	7.75 in		PN 64	230 mm
	Class 600	8.50 in		PN 100	320 mm
3 in	Class 150	8.75 in	DN 100	PN 40	240 mm
	Class 300	8.75 in		PN 64	250 mm
	Class 600	9.50 in		PN 100	260 mm
4 in	Class 150	9.50 in	DN 150	PN 16	305 mm
	Class 300	9.50 in		PN 40	320 mm
	Class 600	10.50 in		PN 64	360 mm
6 in	Class 150	12.00 in		PN 100	360 mm
	Class 300	12.75 in	DN 200	PN 16	381 mm
	Class 600	14.75 in		PN 40	396 mm
8 in	Class 150	15.00 in		PN 64	443 mm
	Class 300	15.75 in	PN 100	443 mm	
	Class 600	18.00 in	DN 250	PN 40	411 mm
10 in	Class 150	15.00 in		PN 64	481 mm
	Class 300	16.20 in	DN 300	PN 40	459 mm
12 in	Class 150	17.00 in		PN 64	513 mm
	Class 300	18.20 in			

- (a) For 3/4 to 4 in sizes, overall face-to-face length (D) tolerance is ±0.05 in.
For 6 to 12 in sizes overall face-to-face length (D) tolerance is ±0.250 in.
- (b) For DN 15 to DN 100 sizes, overall face-to-face length (D) tolerance is ±1.3 mm.
For DN 150 to DN 300 sizes, overall face-to-face length (D) tolerance is ±6.4 mm.
- (c) The DN 50 PN 40 flange may be used with a PN 25 mating flange.

ORDERING INSTRUCTIONS

1. Model Number
2. Flow Data:
 - a. Maximum, minimum, and normal flow rate.
 - b. Fluid composition and viscosity at operating temperatures.
 - c. Fluid density or relative density (specific gravity).
 - d. Maximum, minimum, and normal operating temperatures.
 - e. Maximum, minimum, and normal operating pressures.
 - f. Mating pipe schedule.
 - g. Type and location (distance) of up-stream disturbances.
3. Calibration information (analog output only); maximum flow rate for 20 mA output.
4. Electrical Classification
5. Optional Features
6. Customer Tag Data

PATENT NOTICE

This product and its components are protected by one or more of the following U.S. Patents.

3,948,098; 4,085,614; 4,520,678; 5,003,827 and 5,209,125. Corresponding patents have been issued or are pending in other countries.

OTHER M&I PRODUCTS

Invensys Foxboro provides a broad range of measurement and instrument products, including solutions for pressure, flow, analytical, positioners, temperature, controlling and recording. For a listing of these offerings, visit the Invensys Foxboro web site at:

www.foxboro.com/instrumentation

33 Commercial Street
Foxboro, MA 02035-2099
United States of America
www.foxboro.com
Inside U.S.: 1-866-746-6477
Outside U.S.: 1-508-549-2424
or contact your local Foxboro
representative.
Facsimile: 1-508-549-4999

Invensys, Foxboro, FlowExpertPro, and I/A Series are trademarks of Invensys plc, its subsidiaries, and affiliates.
All other brand names may be trademarks of their respective owners.

Copyright 1994-2008 Invensys Systems, Inc.
All rights reserved

MB 010

Printed in U.S.A.

0608