

8000A Series Compact Magnetic Flowtubes Wafer Body, Ceramic- or pfa-Lined 1.6 to 150 mm (1/16 to 6 in) Line Sizes



These compact, ceramic- or pfa-lined, wafer body flowtubes, together with a Model IMT25 Magnetic Flow Transmitter, combine to form an easy-to-use, versatile, dc pulsed Magnetic Flowmeter. The flowmeter is compatible with most conductive liquids, and produces a measurement signal directly proportional to volumetric flow rate. These flowtubes are offered in 1.6 to 150 mm (1/16 to 6 in) sizes. As symbolized by the CE Logo marking on the product, these flowtubes conform to the applicable European Union directives.

FEATURES

- Compact design.
- Ceramic lining excellent selection for high temperature and highly abrasive processes.
- Retained pfa lining can withstand pressure and temperature extremes. Excellent in corrosive environments. Excellent blistering resistance.
- Proven electrode seal design.
- Minimum fluid conductivity of 5 μ s/cm with recommended cable selection and installation.
- A large selection of flat head electrode materials offered depending on flowtube lining. Conical head electrodes (316 ss and Hastelloy C) are also available for pfa-lined flowtubes.
- Large electrode surface area means less sensitivity to entrained air.
- Tapered inlets reduce profile effects.
- Wafer body mounts between ANSI or metric flanges.
- NEMA 4X construction for environmental and corrosion resistant protection.
- Used with remote- or integrally-mounted transmitters.
- Total quality management including ISO 9001 Certification.
- Standard 2-year warranty.

SUPERIOR REPUTATION FOR DEPENDABILITY AND QUALITY

Foxboro introduced magnetic flow measurement systems to the process industries in 1954 and has demonstrated the broadest and most time-proven application expertise with tens of thousands of successful installations.

AN INTELLIGENT PATH TO MAGNETIC FLOW SYSTEMS

The merging of the latest technology in flowtube design and a microprocessor-based transmitter provides the process industries a significant advancement in liquid flow measurement. The flowmeter can provide 4 to 20 mA dc, pulse, and digital outputs, based on FoxCom, HART, or FOUNDATION Fieldbus communication protocol.

DESIGNED FOR WIDE VARIETY OF PROCESSES

These compact, lightweight, wafer body, ceramic- or pfa-lined flowtubes, with a large selection of electrode materials, provide excellent corrosion and abrasion resistance. These features allow for higher flow velocities (therefore greater rangeability) and also make them suitable for all types of processes including those involving high pressure, high temperature, or vacuum service.

PULSED dc FLOWTUBE USED WITH REMOTE- OR INTEGRALLY-MOUNTED TRANSMITTER

The 8000A Series Magnetic Flowtubes are calibrated for use with pulsed dc coil excitation. Foxboro offers the I/A Series Intelligent Magnetic Flow Transmitter (Model IMT25) for use with these flowtubes.

The IMT25 Transmitter is offered for installation in a remote location (pipe or surface mounting), or integrally mounted to the flowtube, 15 to 150 mm (1/2 to 6 in) sizes only.

FLOWTUBE CALIBRATION

All flowtubes are wet calibrated to verify their specified accuracy with traceability to the U.S. National Institute of Science and Technology (NIST).

LOW POWER CONSUMPTION

All flowmeter configurations are designed to consume less than 24 W of power at reference voltage and frequency.

NUMEROUS CONFIGURATIONS AVAILABLE

Flowtube sizes range from 1.6 to 150 mm (1/16 to 6 in) for ceramic-lined flowtubes, and 15 to 150 mm (1/2 to 6 in) for pfa-lined flowtubes. Depending on the flowtube size selected, ceramic-lined flowtubes are offered with tantalum or platinum electrodes, while pfa-lined flowtubes are available with tantalum-tungsten, 316 ss, Hastelloy C, platinum-iridium, or titanium electrodes. All flowtubes can be mounted between Class 150 or 300 flanges, or Metric PN 10 to PN 40 flanges.

CONICAL ELECTRODES OFFERED

Conical electrodes are offered in both Hastelloy C and 316 ss with pfa-lined flowtubes sized 25 mm (1 in) or larger. These are excellent selections for applications where processes can coat conventional flush-with-lining electrodes. With conicals, the electrode point extends into the process where the process fluid tends to sweep the electrodes clean.

WEATHERPROOF AND CORROSION RESISTANT CONSTRUCTION

These flowtubes are designed to operate in harsh outdoor or in-plant environments. The flowtube enclosure is weatherproof as defined by IEC IP66 and provides the watertight and corrosion-resistant protection of NEMA Type 4X. An accidental submergence flowtube housing is also offered for use with remote-mounted transmitters.

PED QUALIFICATION

This product is qualified for SEP (Standard Engineering Practice) Category 1 with Group 2 fluids (nonhazardous).

TQM — TOTAL QUALITY MANAGEMENT

The TQM program is Invensys Process Systems commitment to total product quality and customer satisfaction.

Invensys Process Systems has met all of the requirements of the International Quality Standard 9001 and was officially certified in April of 1991 for the "Design and Manufacturing of Process Control and Automation Equipment". The certification applies to the entire US-based operations including manufacturing, design/development, production, installation, and service. The certification has remained valid since the initial award, as Invensys Process Systems has successfully passed scheduled periodic audits performed by the certifying agency.

OPERATING CONDITIONS

Operating Conditions – Ceramic-Lined Flowtube

Influence	Reference Operating Conditions	Operating Condition Limits	
		with Remote-Mounted Transmitter	with Integrally-Mounted IMT25
Ambient Temperature	25 ±2°C (77 ±3.6°F)	–40 and +70°C (–40 and +158°F)	–30 and +70°C(c) (–22 and +158°F)
Process Temperature	25 ±2°C (77 ±3.6°F)	–40 and +204°C (–40 and +400°F)	–40 and +121°C (–40 and +250°F)
Process Pressure 1.6 to 50 mm (1/16 to 2 in) See Note (a),(b)	0.517 MPa (75 psi)	Full Vacuum and: 5.1 MPa at 38°C (740 psi at 100°F) and 4.4 MPa at 204°C (635 psi at 400°F)	Full Vacuum and: 5.1 MPa at 38°C (740 psi at 100°F) and 4.7 MPa at 121°C (665 psi at 250°F)
Process Pressure 80 to 150 mm (3 to 6 in) See Note (a),(b)	0.517 MPa (75 psi)	Full Vacuum and: 4.6 MPa at 38°C (675 psi at 100°F) and 4.0 MPa at 204°C (580 psi at 400°F)	Full Vacuum and: 4.6 MPa at 38°C (675 psi at 100°F) and 4.3 MPa at 121°C (625 psi at 250°F)

- (a) The pressure-temperature values listed are for the flowtube itself. The flange type, rating, and material used during installation may have a lower pressure-temperature limit than the flowtube. **DO NOT** exceed the applicable flange pressure-temperature limit of the flowtube or flange, whichever is less.
- (b) Maximum allowable step change in temperature difference between process and ceramic lining is an increase of 125°C (225°F) and a decrease of 75°C (135°F).
- (c) With IMT25 Integral Display option B, lower limit is –20°C (–4°F). See PSS 1-6F5 A (FoxCom and HART) or PSS 1-6F5 B (Fieldbus) for transmitter Normal Operating Conditions.

Operating Conditions – pfa-Lined Flowtube

Influence	Reference Operating Conditions	Operating Condition Limits	
		with Remote-Mounted Transmitter	with Integrally-Mounted IMT25
Ambient Temperature	25 ±2°C (77 ±3.6°F)	–40 and 70°C (–40 and +158°F)	–30 and +70°C(b) (–22 and +158°F)
Process Temperature	25 ±2°C (77 ±3.6°F)	–40 and +180°C (–40 and +356°F)	–40 and +121°C (–40 and +250°F)
Process Pressure See Note (a)	0.517 MPa (75 psi)	Full Vacuum and: 5.1 MPa at 38°C (740 psi at 100°F) and 4.4 MPa at 180°C (645 psi at 356°F)	Full Vacuum and: 5.1 MPa at 38°C (740 psi at 100°F) and 4.7 MPa at 121°C (665 psi at 250°F)

- (a) The pressure-temperature values listed are for the flowtube itself. The flange type, rating, and material used during installation may have a lower pressure-temperature limit than the flowtube. **DO NOT** exceed the applicable flange pressure-temperature limit of the flowtube or flange, whichever is less.
- (b) With IMT25 Integral Display option B, lower limit is –20°C (–4°F). See PSS 1-6F5 A (FoxCom and HART) or PSS 1-6F5 B (Fieldbus) for transmitter Normal Operating Conditions.

PERFORMANCE SPECIFICATIONS

(Combined Flowtube and Transmitter System under Reference Operating Conditions)

Flowmeter System

8000A Flowtube with IMT25 Transmitter (FoxCom and HART)
8000A Flowtube with IMT25 Transmitter (FOUNDATION Fieldbus)

Refer to

PSS 1-6F5 A
PSS 1-6F5 B

FUNCTIONAL SPECIFICATIONS

Process Pressure and Temperature Limits

Refer to applicable tables in “Operating Conditions” section.

Minimum and Maximum Upper Range Values

See Table 1. In this table, the minimum upper range value (URV) is not the lowest flow rate that the flowtube can measure; it is the lowest flow rate which can correspond to the 20 mA signal. For example: for the 1/2 in flowtube, the minimum range is 0 to 1.0 U.S. gpm, and this will generate 4 to 20 mA.

Lining and Electrode Material Selection Guide

Ceramic provides excellent abrasion resistance and is suitable for high pressure, high temperature, or vacuum service process applications. PFA is an equally preferred lining except it should not be used

in severe abrasive processes. It is, however, the recommended lining in processes requiring excellent resistance to thermal shock and liner coating problems. Refer to Table 2. Also, refer to TI 27-71f for an application guide for the use of flowtube linings and electrode materials vs. approximately 150 different process fluids.

Process Fluid Conductivity and Signal Cable Length

The maximum allowable cable length is a function of the cable type, process fluid conductivity, and whether the cables are in the same or separate conduits. Standard system accuracy will be maintained when the installations are in accordance with Table 3.

Table 1. Minimum and Maximum Upper Range Values

Nominal Line Size		Nominal Tube I.D.		Flow Velocity Minimum and Maximum URV		Flow Rate Minimum and Maximum URV	
mm	in	mm	in	m/s	ft/s	L/min	U.S. gpm
1.6	1/16	1.57	0.062	0.97 and 10	3.19 and 33	0.11 and 1.1	0.03 and 0.3
3	1/8	3.175	0.125	0.56 and 10	1.83 and 33	0.26 and 4.9	0.07 and 1.3
6	1/4	5.33	0.210	0.51 and 10	1.67 and 33	0.68 and 13.6	0.18 and 3.6
15	1/2	12.7	0.50	0.50 and 10	1.64 and 33	3.8 and 76	1.0 and 20
25	1	23.6	0.93	0.50 and 10	1.64 and 33	13.2 and 265	3.5 and 70
40	1 1/2	37.1	1.46	0.50 and 10	1.64 and 33	34.1 and 644	9.0 and 170
50	2	45.0	1.77	0.50 and 10	1.64 and 33	49 and 946	13 and 250
80	3	70.6	2.78	0.50 and 10	1.64 and 33	117 and 2366	31 and 625
100	4	94.0*	3.70*	0.50 and 10	1.64 and 33	208 and 4164	55 and 1100
150	6	139.7*	5.50*	0.50 and 10	1.64 and 33	462 and 9236	122 and 2440

*I.D. of 100 and 50 mm (4 and 6 in) pfa-lined tubes are slightly smaller than shown.

Table 2. Flowtube Lining Selection Guide

Flowtube Construction	Process Fluid Characteristic (a)(d)					
	Clean	Mild Corrosion	Severe Corrosion	Mild Abrasion	Severe Abrasion (b)	Mild Corrosion and Abrasion
pfa Lining	A	A	A	B	X	B
Ceramic Lining	A	A	B	A	B (c)	A

(a) A = Preferred selection. Generally considered the best choice.

B = Satisfactory selection. Reasonable life under most conditions.

X = Not recommended. Generally considered unacceptable.

(b) Severe abrasion rating also includes/considers effects on electrode.

(c) This characteristic can be upgraded to A for process fluid velocities less than 0.91 m/s (3 ft/s).

(d) This product is qualified for SEP (Standard Engineering Practice) Category 1 with Group 2 fluids (nonhazardous).

FUNCTIONAL SPECIFICATIONS (Cont.)

Table 3. Process Fluid Conductivity and Cabling

Maximum Cable Length	Minimum Fluid Conductivity	Signal and Coil Drive Cables
300 m (1000 ft)	5 μ S/cm	Signal and Coil Drive Cables in separate conduit. Signal Cable to be Foxboro Part No. R0101ZS (feet) or B4017TE (metres).
225 m (750 ft)	5 μ S/cm	Signal and Coil drive cables in same conduit. Signal Cable to be Foxboro Part No. R0101ZS (feet) or B4017TE (metres).
150 m (500 ft)	20 μ S/cm	Signal cable may be in same conduit as coil drive cable. Signal cable to be good quality twisted shielded pair, preferable no smaller than 1.0 mm ² (or 18 AWG) for mechanical considerations (Belden 8760 or 9318, Alpha 5610/1801 or 5611/1801, or equivalent).

(a) Values in table are fluid conductivity minimums, and maximum distance between transmitter and flowtube. Refer to TI 27-072 for conductivities of various process liquids.

ELECTRICAL SAFETY SPECIFICATIONS

Testing Laboratory, Types of Protection and Area Classification	Application Conditions	Electrical Safety Design Code
CSA Class I, Division 2, Groups A, B, C, and D; Class II, Division 2, Groups F and G; and Class III, Division 2 hazardous locations.	Temperature Class T6, Ta = 70°C.	CNZ
FM nonincendive, Class I, Division 2, Groups A, B, C, and D; suitable for Class II, and III, Division 2, Groups F and G hazardous locations.	Temperature Class T6, Ta = 70°C. For use on non-hazardous process only.	FNA
CENELEC EEx e ia IIC, Zone 1.	Temperature Class T3-T6. Electrodes are intrinsically safe when connected to certified intrinsically safe equipment.	ESB
CENELEC nonincendive, Ex N IIC, Zone 2.	Temperature Class T2-T6.	KNZ
No certification	—	ZZZ

PHYSICAL SPECIFICATIONS

HOUSING CONSTRUCTION

These flowtubes are offered with a selection of the following housing construction: a Weatherproof construction housing and an Accidental Submergence construction housing. See paragraphs below.

Weatherproof Construction Housing

This housing is designed for harsh in-plant or outdoor environments. It is weatherproof as defined by IEC IP65, and provides the watertight and corrosion-resistant protection of NEMA Type 4X. Select Housing Code -G.

Accidental Submergence Construction Housing

Only offered when transmitter is mounted in a remote location. The weatherproof flowtube housing is factory sealed to allow 48 hours of operation after being accidentally submerged in a maximum depth of 9 m (30 ft) of water. A field kit is provided to the customer for final sealing after site installation. Select Housing Code -H.

Materials

FLOWTUBE HOUSING

Ductile iron

JUNCTION BOX (w/REMOTE TRANSMITTER)

Cast aluminum

FLOWTUBE LINER

Ceramic (99.5% aluminum oxide) or pfa (perfluoroalkoxy)

ELECTRODES (CERAMIC-LINED FLOWTUBES)

Platinum. Tantalum for 1/16 to 1/4 in sizes only

ELECTRODES (pfa-LINED FLOWTUBES)

Tantalum-Tungsten

316 ss

Conical 316 ss (1 to 6 in sizes only)

Hastelloy C

Conical Hastelloy C (1 to 6 in sizes only)

Platinum-Iridium

Titanium

FLANGE GASKETS

Gylon (ptfe/barium sulfate) for ceramic-lined flowtubes. User provides own gasket on pfa-lined flowtubes.

JUNCTION GASKET

Box/Cover Silicone Sponge Rubber

Box/Housing Silicone Rubber/Cork

LOCATOR CAM

Nylon

Flowtube Construction

CERAMIC-LINED TUBES

One-piece all ceramic construction

pfa-LINED TUBES

Cast 304 ss or 305 ss tube with reinforced and retained pfa liner

Flowtube End Connections and Construction

Wafer body. Mounts between DIN PN 10 to PN 40 flanges; or ANSI Class 150 or 300 R.F. flanges.

Flange bolting kits are available from Foxboro for the ANSI Class 150 and 300 flanges, and DIN PN 10 and PN 16 flanges.

Flowtube-Mounted Transmitter (1/2 to 6 in only)

The transmitter is bolted to the terminal housing of the flowtube. See "Dimensions—Nominal" section.

Mounting Position

The flowtube can be mounted at any orientation without degrading performance. The only requirements are that the flowtube be completely full with the process liquid during measurement, and that the electrodes be in horizontal plane. Installation in a vertical pipeline with flow going upward is ideal. Recommended straight run of pipe is five pipe diameters upstream and three pipe diameters downstream.

Electrical Connections

Refer to "DIMENSIONS—NOMINAL" section.

Grounding Rings

Needed if mating piping is nonmetallic or lined. When required, grounding rings must be at both ends of the flowtube. Grounding rings (i.e., orifice plates) are available from Invensys Process Systems, if needed.

Approximate Flowtube Mass (see Note)

Flowtube Size		With Ceramic Lining	With pfa Lining
mm	in		
1.6	1/16	2.3 kg (5 lb)	Not Applicable
3	1/8	2.3 kg (5 lb)	Not Applicable
6	1/4	2.3 kg (5 lb)	Not Applicable
15	1/2	2.3 kg (5 lb)	1.7 kg (3.7 lb)
25	1	3.0 kg (6.6 lb)	2.4 kg (5.4 lb)
40	1 1/2	3.5 kg (7.7 lb)	2.9 kg (6.5 lb)
50	2	4.5 kg (9.9 lb)	3.5 kg (7.7 lb)
80	3	7.0 kg (15.4 lb)	7.3 kg (16.1 lb)
100	4	10.0 kg (22 lb)	11.8 kg (26.4 lb)
150	6	17.7 kg (39 lb)	22.7 kg (50 lb)

NOTE

See applicable transmitter PSS for transmitter mass and add to flowtube mass to get the assembled mass of the transmitter integrally mounted to the flowtube. Integral transmitter mounting only available with flowtube sizes 1/2 in and above.

OPTIONAL SELECTIONS AND ACCESSORIES

Foxboro Signal Cable

For Remote-Mounted Transmitter applications only. Two-core (two-conductor), multiscreened (multi-shielded) cable with two driven screens (shields). Maximum length is 300 m (1000 ft). This cable (Part Number R0101ZS for length in feet, or B4017TE for length in metres) is identified here for reference only. This cable is generally specified with transmitter order. Refer to Table 3.

Options -A, -B, -C, or -D: Mounting Hardware

Flange bolt kits available for installing flowtubes between ANSI Class 150, ANSI Class 300, PN 10 or PN 16 flanges. Select Model Code Optional Selection -A, -B, -C, or -D, respectively.

Option -G: Cable Glands

For Remote-Mounted Transmitter and nonconduit applications only. Used to provide rain tight, strain relieved entrance for 6.8 to 12.2 mm (0.27 to 0.48 in) diameter cable. External 1/2 NPT threads into internal 1/2 NPT thread on transmitter or flowtube cable entry surface. Body and seal nut are nylon, and compression gland is neoprene. Selectable using Model Code Optional Selection -G.

Grounding (Protective) Rings

Two grounding rings are required, one on each end of the flowtube, if mating piping is lined or nonmetallic. For 316 ss grounding rings, see table below.

316 ss Grounding Rings

Line Size		Ring Thickness		Foxboro Part Number (a)
mm	in	mm	in	
1.6	1/16	3.2	0.13	D0156BW
3	1/8	3.2	0.13	D0156BW
6	1/4	3.2	0.13	D0156BW
15	1/2	3.2	0.13	L0118SB
25	1	3.2	0.13	L0118SC
40	1 1/2	3.2	0.13	L0118SD
50	2	3.2	0.13	L0118SE
80	3	3.2	0.13	A0129NE
100	4	3.2	0.13	A0129NF
150	6	3.2	0.13	A0129NK

(a) Part number represents 1 grounding ring.

NOTE

For Hastelloy C, Monel, Tantalum, or Titanium grounding rings, contact Invensys Process Systems.

MODEL CODES

Ceramic Lined Flowtubes

Description	Model
Compact Magnetic Flowtube, 1.6 mm (1/16 in) Line Size (a)	801SA
Compact Magnetic Flowtube, 3 mm (1/8 in) Line Size (a)	801EA
Compact Magnetic Flowtube, 6 mm (1/4 in) Line Size (a)	801QA
Compact Magnetic Flowtube, 15 mm (1/2 in) Line Size	800HA
Compact Magnetic Flowtube, 25 mm (1 in) Line Size	8001A
Compact Magnetic Flowtube, 40 mm (1 1/2 in) Line Size	801HA
Compact Magnetic Flowtube, 50 mm (2 in) Line Size a	8002A
Compact Magnetic Flowtube, 80 mm (3 in) Line Size	8003A
Compact Magnetic Flowtube, 100 mm (4 in) Line Size	8004A
Compact Magnetic Flowtube, 150 mm (6 in) Line Size	8006A
Tube Construction/End Connection Wafer Body, Mounts between ANSI Class 150 or 300 Flanges, or Metric PN 10 to PN 40 Flanges	–W
Lining Material Ceramic	C
Transmitter Mounting Remote Mounting to a Pipe or Surface - All Line Sizes Flowtube Mounting to IMT25 Transmitter - 800HA to 8006A Only	R I
Electrodes Tantalum - 801SA to 801QA Platinum - Ceramic-Lined	–B –P
Coil Drive/Supply Pulsed dc (From IMT25 Transmitter)	J
Housing Construction NEMA 4X Housing; Used with Remote- or Integrally-Mounted Transmitter Accidental Submergence; Used with Remote-Mounted Transmitter Only (b)	G H
Electrical Safety (also see Electrical Safety Specifications section) CSA, Class I, II, III; Division 2 FM, n Nonincendive, Division 2 CENELEC, EEx e ia IIC, Zone 1 European, Nonincendive, Zone 2 No Certification	CNZ FNA ESB KNZ ZZZ
Optional Selection(s) Mounting Hardware for ANSI Class 150 Flanges Mounting Hardware for ANSI Class 300 Flanges Mounting Hardware Metric PN 10 Flanges Mounting Hardware Metric PN 16 Flanges Cable Glands for Nonconduit Applications (Select with Remote Transmitter Mounting Code R only) (c)	–A –B –C –D –G
Examples: 8001A–WCR–PJHCGZ–AG	

- (a) These flowtubes are designed and calibrated for installation between 15 mm (1/2 in) flanges.
- (b) Sealed for accidental operation under water up to 9 m (30 ft) deep for 48 hours. Supplied with a field sealing kit for final sealing by user after installation.
- (c) The cable glands (–G option) provide a sealed cable entry for field wiring to the flowtube junction box, and are specified in non-conduit applications. They are not available with CNZ or FNA Electrical Safety Codes.

MODEL CODES (Cont.)

pfa (Perfluoroalkoxy) Lined Flowtubes

Description	Model
Compact Magnetic Flowtube, 15 mm (1/2 in) Line Size	800HA
Compact Magnetic Flowtube, 25 mm (1 in) Line Size	8001A
Compact Magnetic Flowtube, 40 mm (1 1/2 in) Line Size	801HA
Compact Magnetic Flowtube, 50 mm (2 in) Line Size a	8002A
Compact Magnetic Flowtube, 80 mm (3 in) Line Size	8003A
Compact Magnetic Flowtube, 100 mm (4 in) Line Size	8004A
Compact Magnetic Flowtube, 150 mm (6 in) Line Size	8006A
<u>Tube Construction/End Connection</u>	
Wafer Body, Mounts between ANSI Class 150 or 300 Flanges, or Metric PN 10 to PN 40 Flanges	-W
<u>Lining Material</u>	
pfa (Perfluoroalkoxy)	P
<u>Transmitter Mounting</u>	
Remote Mounting to a Pipe or Surface - All Line Sizes	R
Flowtube Mounting to IMT25 Transmitter - 800HA to 8006A Only	I
<u>Electrodes</u>	
Tantalum-Tungsten	-B
Conical 316 ss - 8001A to 8006A	-C
Hastelloy C	-H
Conical Hastelloy C - 8001A to 8006A	-K
Platinum-Iridium	-P
316 ss	-S
Titanium	-T
<u>Coil Drive/Supply</u>	
Pulsed dc (From IMT25 Transmitter)	J
<u>Housing Construction</u>	
NEMA 4X Housing; Used with Remote- or Integrally-Mounted Transmitter	G
Accidental Submergence; Used with Remote-Mounted Transmitter Only (b)	H
<u>Electrical Safety (also see Electrical Safety Specifications section)</u>	
CSA, Class I, II, III; Division 2	CNZ
FM, n Nonincendive, Division 2	FNA
CENELEC, EEx e ia IIC, Zone 1	ESB
European, Nonincendive, Zone 2	KNZ
No Certification	ZZZ
<u>Optional Selection(s)</u>	
Mounting Hardware for ANSI Class 150 Flanges	-A
Mounting Hardware for ANSI Class 300 Flanges	-B
Mounting Hardware Metric PN 10 Flanges	-C
Mounting Hardware Metric PN 16 Flanges	-D
Cable Glands for Nonconduit Applications (Select with Remote Transmitter Mounting Code R only) (c)	-G
Examples: 8002A-WPI-SJGFNA-A	

- (a) Sealed for accidental operation under water up to 9 m (30 ft) deep for 48 hours. Supplied with a field sealing kit for final sealing by user after installation.
- (b) The cable glands (-G option) provide a sealed cable entry for field wiring to the flowtube junction box, and are specified in non-conduit applications. They are not available with CNZ or FNA Electrical Safety Codes.

DIMENSIONS—NOMINAL

mm
in

**801SA-WCR TO 801HA-WCR CERAMIC-LINED FLOWTUBES
USED WITH REMOTE-MOUNTED TRANSMITTERS**

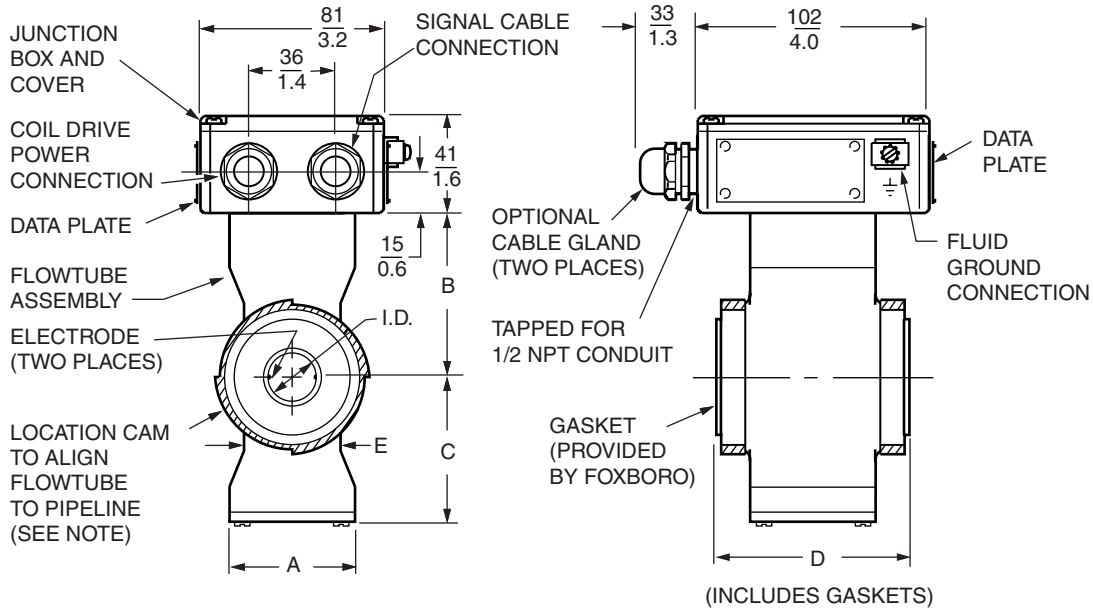

Flowtube Model	Nom. Line Size		Actual I.D.	Nominal Dimensions				
	mm	in		A	B	C	D	E
801SA-WCR (a)	1.6	1/16	<u>1.57</u> 0.062	<u>53</u> 2.1	<u>61</u> 2.4	<u>58</u> 2.3	<u>77.7</u> 3.06	<u>28</u> 1.1
801EA-WCR (a)	3	1/8	<u>3.18</u> 0.125	<u>53</u> 2.1	<u>61</u> 2.4	<u>58</u> 2.3	<u>77.7</u> 3.06	<u>28</u> 1.1
801QA-WCR (a)	6	1/4	<u>5.33</u> 0.210	<u>53</u> 2.1	<u>61</u> 2.4	<u>58</u> 2.3	<u>77.7</u> 3.06	<u>28</u> 1.1
800HA-WCR	15	1/2	<u>12.70</u> 0.500	<u>53</u> 2.1	<u>61</u> 2.4	<u>58</u> 2.3	<u>77.7</u> 3.06	<u>28</u> 1.1
8001A-WCR	25	1	<u>23.62</u> 0.930	<u>53</u> 2.1	<u>69</u> 2.7	<u>66</u> 2.6	<u>77.7</u> 3.06	<u>41</u> 1.6
801HA-WCR	40	1 1/2	<u>37.08</u> 1.460	<u>53</u> 2.1	<u>84</u> 3.3	<u>76</u> 3.0	<u>88.9</u> 3.50	<u>53</u> 2.1

(a) Designed for installation between 15 mm (1/2 in) flanges.

NOTE

Location CAM is provided with flowtube to simplify its alignment with the following pipeline flanges:
Metric PN 10, PN 16, PN 20, PN 25, and PN 40; and ANSI Class 150 and 300.

DIMENSIONS—NOMINAL (Cont.)

mm
in

8002A-WCR TO 8006A-WCR CERAMIC-LINED FLOWTUBES
USED WITH REMOTE-MOUNTED TRANSMITTERS

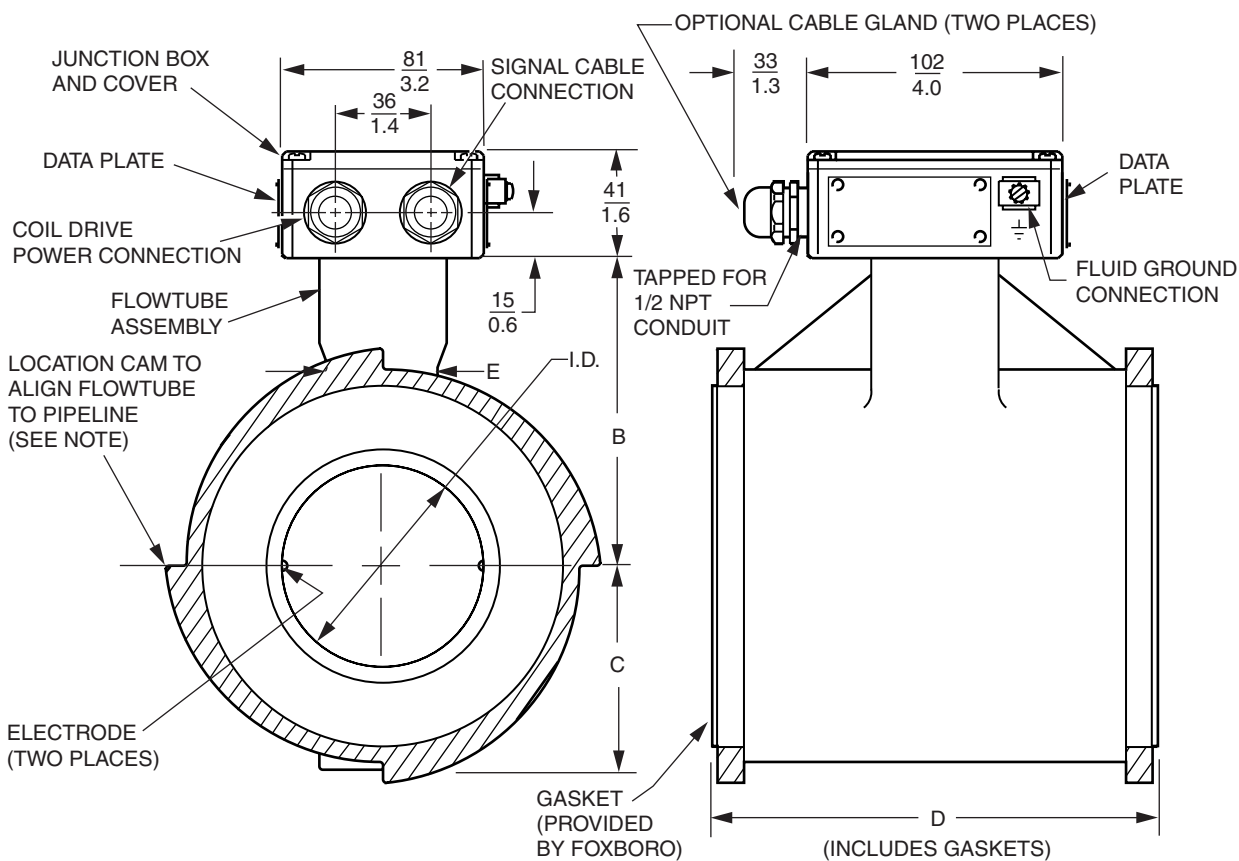

Flowtube Model	Nom. Line Size		Actual I.D.	Nominal Dimensions			
	mm	in		B	C	D	E
8002A-WCR	50	2	<u>45.0</u> 1.77	<u>91</u> 3.6	<u>61</u> 2.4	<u>113.0</u> 4.44	<u>28</u> 1.1
8003A-WCR	80	3	<u>70.6</u> 2.78	<u>107</u> 4.2	<u>76</u> 3.0	<u>155.7</u> 6.13	<u>41</u> 1.6
8004A-WCR	100	4	<u>94.0</u> 3.70	<u>135</u> 5.3	<u>89</u> 3.5	<u>190.5</u> 7.50	<u>41</u> 1.6
8006A-WCR	150	6	<u>139.7</u> 5.50	<u>165</u> 6.5	<u>114</u> 4.5	<u>209.6</u> 8.25	<u>48</u> 1.9

NOTE

Location CAM is provided with flowtube to simplify its alignment with the following pipeline flanges: Metric PN 10, PN 16, PN 20, PN 25, and PN 40; and ANSI Class 150 and 300.

DIMENSIONS—NOMINAL (Cont.)

mm
in

**800HA-WPR TO 801HA-WPR PFA-LINED FLOWTUBES
USED WITH REMOTE-MOUNTED TRANSMITTERS**

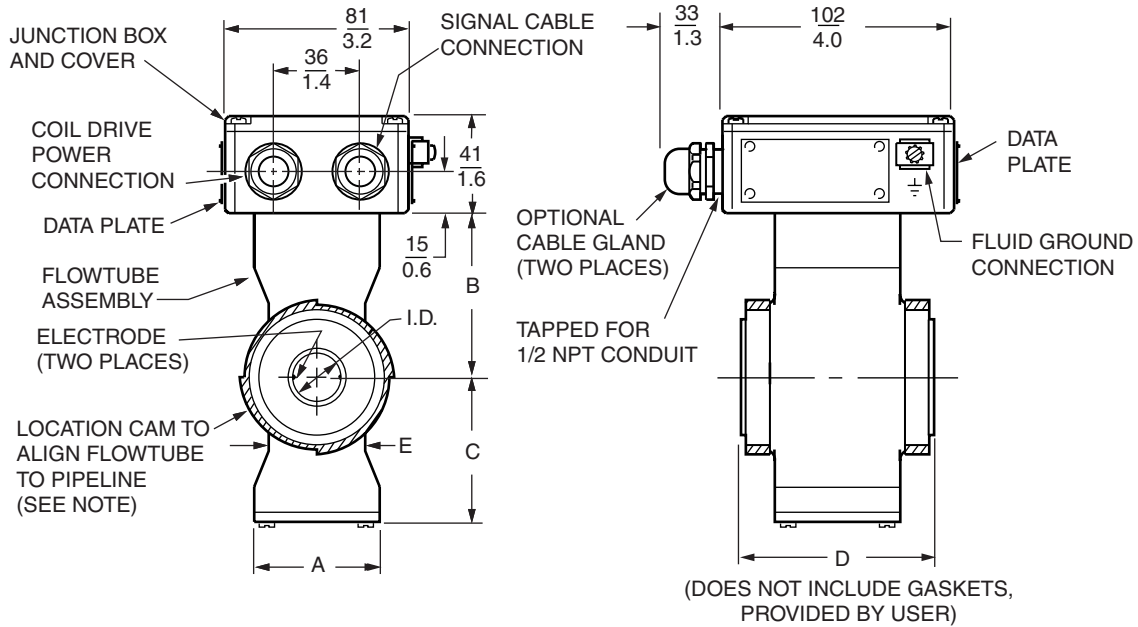

Flowtube Model	Nom. Line Size		Actual I.D.	Nominal Dimensions				
	mm	in		A	B	C	D	E
800HA-WPR	15	1/2	<u>12.70</u> 0.500	<u>53</u> 2.1	<u>61</u> 2.4	<u>58</u> 2.3	<u>71.4</u> 2.81	<u>28</u> 1.1
8001A-WPR	25	1	<u>23.62</u> 0.930	<u>53</u> 2.1	<u>69</u> 2.7	<u>66</u> 2.6	<u>71.4</u> 2.81	<u>41</u> 1.6
801HA-WPR	40	1 1/2	<u>37.08</u> 1.460	<u>53</u> 2.1	<u>84</u> 3.3	<u>76</u> 3.0	<u>82.6</u> 3.25	<u>53</u> 2.1

NOTE

Location CAM is provided with flowtube to simplify its alignment with the following pipeline flanges: Metric PN 10, PN 16, PN 20, PN 25, and PN 40; and ANSI Class 150 and 300.

DIMENSIONS—NOMINAL (Cont.)

mm
in

**8002A-WPA TO 8006A-WPR PFA-LINED FLOWTUBES
USED WITH REMOTE-MOUNTED TRANSMITTERS**

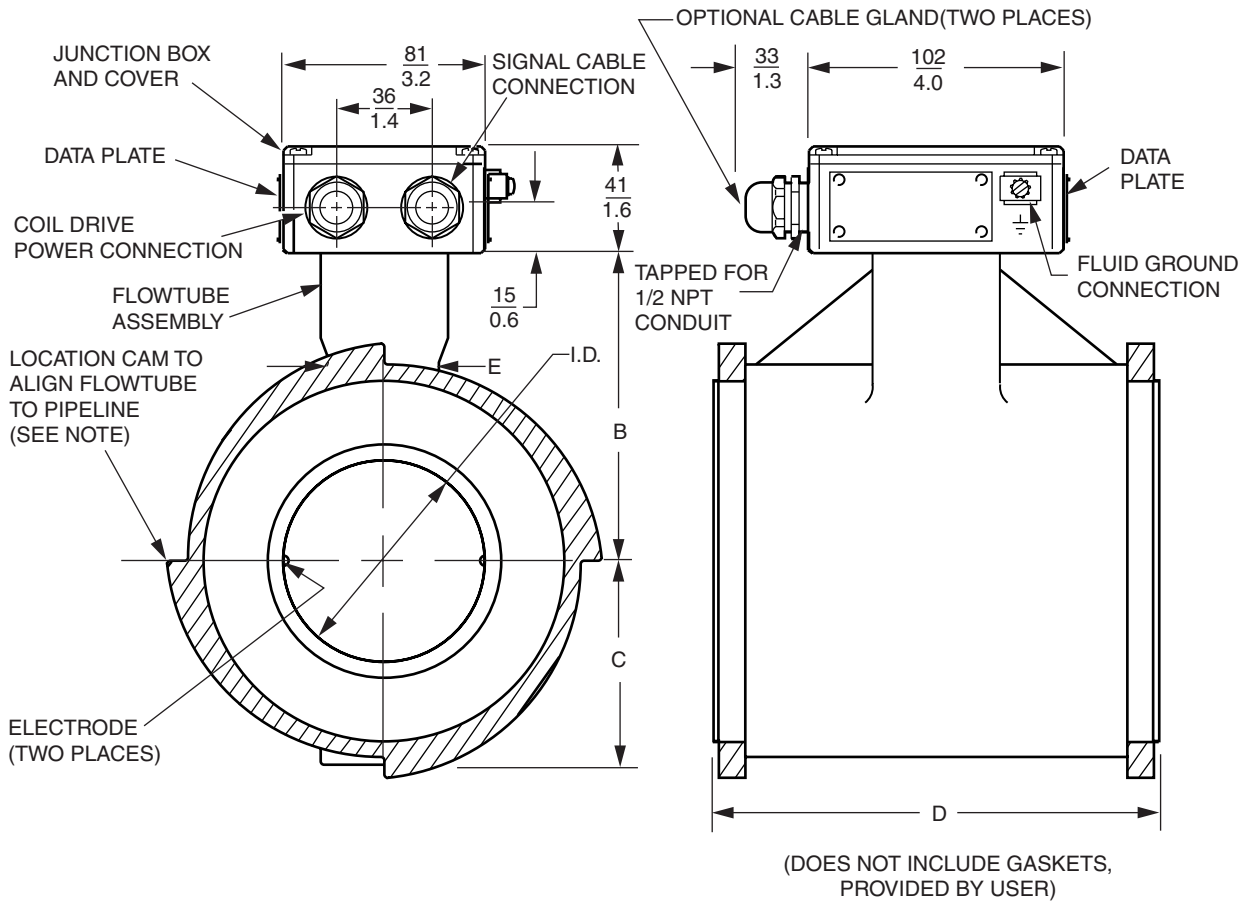

Flowtube Model	Nom. Line Size		Actual I.D.	Nominal Dimensions			
	mm	in		B	C	D	E
8002A-WPR	50	2	<u>45.0</u> 1.77	91 3.6	61 2.4	<u>106.4</u> 4.20	28 1.1
8003A-WPR	80	3	<u>70.6</u> 2.78	107 4.2	76 3.0	<u>149.2</u> 5.88	41 1.6
8004A-WPR	100	4	<u>94.0</u> 3.70	135 5.3	89 3.5	<u>184.2</u> 7.25	41 1.6
8006A-WPR	150	6	<u>139.7</u> 5.50	165 6.5	114 4.5	<u>203.2</u> 8.00	48 1.9

NOTE

Location CAM is provided with flowtube to simplify its alignment with the following pipeline flanges: Metric PN 10, PN 16, PN 20, PN 25, and PN 40; and ANSI Class 150 and 300.

DIMENSIONS—NOMINAL (Cont.)

mm
in

800HA-WCI/WPI TO 8006A-WCI/WPI FLOWTUBE
USED WITH IMT25 FLOWTUBE-MOUNTED TRANSMITTERS

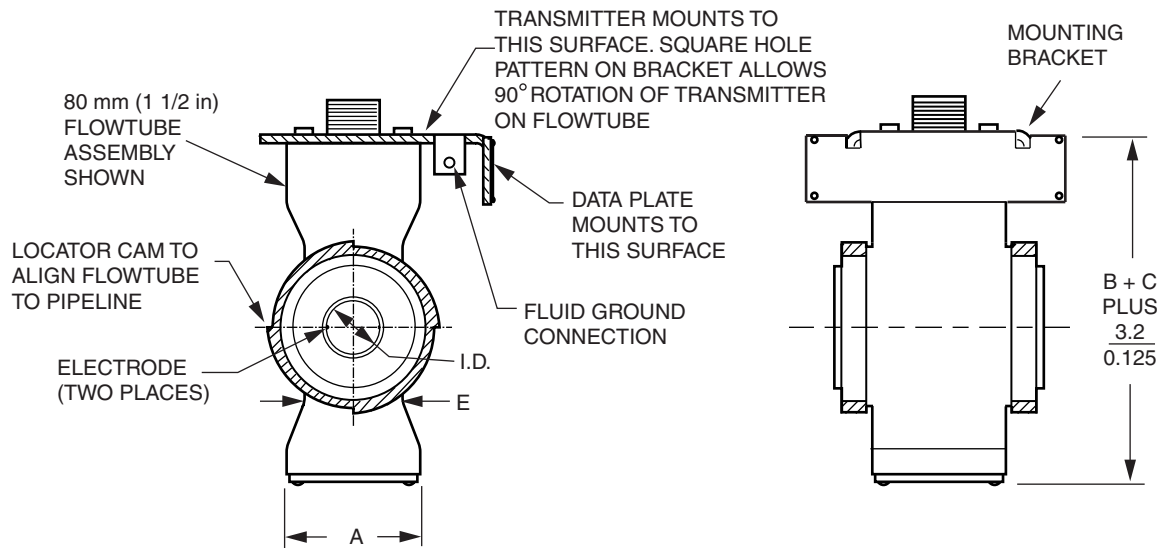

NOTES:

1. SEE PREVIOUS PAGES FOR FLOWTUBE DIMENSIONS.
2. SEE APPLICABLE TRANSMITTER PSS FOR TRANSMITTER DIMENSIONS.
3. FIELD WIRING IS THROUGH TRANSMITTER CONDUIT HOLES. SEE TRANSMITTER PSS.
4. DIMENSION "A" ONLY APPLIES TO 1.6 TO 40 mm (1/16 TO 1 1/2 in) SIZES.

DIMENSIONS—NOMINAL (Cont.)

mm
in

8001A-WCI/WPI FLOWTUBE SHOWN MOUNTED TO IMT25 TRANSMITTER

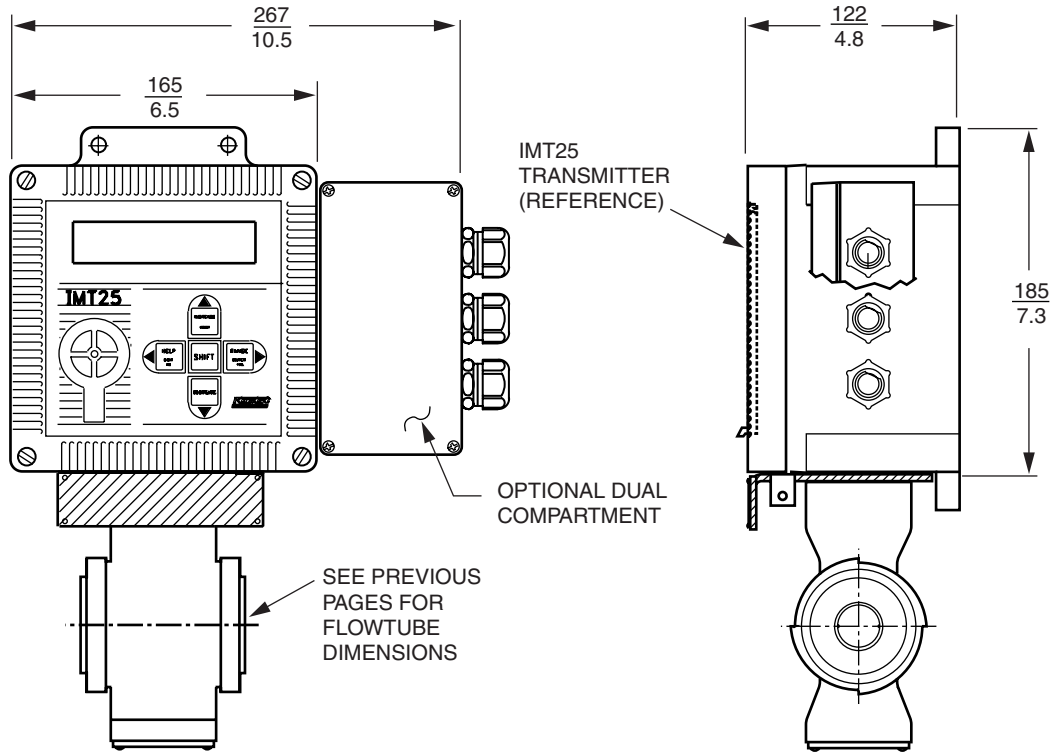

ORDERING INSTRUCTIONS

1. Model Number
2. Flow Rate and Engineering Units Required. Value specified must be within minimum and maximum upper range values listed in Table 1.
3. Process Pressure-Temperature Range
4. Process Composition and Conductivity
5. Grounding Rings (if mating piping is nonmetallic, or lined metallic piping)
6. Optional Selections (if not included in Model Number)
7. User Tag Data

OTHER M&I PRODUCTS

Invensys Process Systems provides a broad range of measurement and instrument products, including solutions for pressure, flow, analytical, positioners, temperature, controlling and recording. For a listing of these offerings, visit the Invensys Foxboro web site at:

www.foxboro.com/instrumentation