

12A Series Pneumatic Temperature Transmitters



These dependable transmitters accurately measure temperature between -220 and $+760^{\circ}\text{C}$ (-350 and $+1400^{\circ}\text{F}$) and transmit a standard pneumatic signal to receivers which may be up to several hundred metres or yards away.

The 12A Series transmitters are used with pneumatic receivers to indicate, record, or control the temperature of processes. By means of the standard Foxboro force-balance mechanism, these transmitters produce a 20 to 100 kPa, 3 to 15 psi, or 0.2 to 1.0 bar or kg/cm^2 output signal proportional to the temperature at the sensor.

SIMPLE FORCE-BALANCE MECHANISM

The Foxboro force-balance mechanism has no moving parts, links, secondary levers, or pivots. This mechanism has proven itself trouble-free and ensures stable, dependable operation.

SIMPLE RANGE CHANGING

A single screwdriver adjustment allows the instrument zero to be elevated or suppressed 100% of span. Additional elevation or suppression may require a change in the ambient compensating bellows. To change the span, 1 or more of 3 readily installed parts (the thermal system, range spring, and compensating bellows) are involved.

HIGH ACCURACY

The accuracy of these transmitters, even for narrow span suppressed-zero ranges, is a function of span and is independent of the upper range value.

EASY TO INSTALL

Versatile mounting bracket together with compact construction permits many alternative mounting positions.

FAST RESPONSE

The response is comparable to that of an unsheathed thermocouple.

MODEL CODE

Description	Model
<p>Transmitter with General Purpose Thermal System This transmitter uses a Sensor Code 3542. A Sensor Code 3542 is a Class IIIB case-compensated gas-filled thermal system; it has an adjustable union and bendable extension; the sensor material is AISI Type 316 stainless steel (316 ss); and the diameter of the sensitive length is 9.53 mm (0.375 in).</p>	12A
<p>Transmitter with Cryogenic Thermal System This transmitter also uses a Sensor Code 3542. See 12A for Sensor Code 3542 description.</p>	12A-C
<p>Transmitter with High Temperature Thermal System This transmitter uses a Sensor Code 3482. A Sensor Code 3482 is a Class IIIB case-compensated gas-filled thermal system; it has a fixed union and bendable extension; the sensor material is Inconel; and the diameter of the sensitive length is 9.53 mm (0.375 in).</p>	12A-H
<p>Transmitter with Sanitary Thermal System <u>Sensor Code</u> Class IIIB case-compensated gas-filled thermal system; plain, bendable extension; 316 ss sensor material; 9.53 mm (0.375 in) sensitive length diameter</p>	12AS
<p><u>Connectors(a)</u> 16A Bevel Seat Type 16AMP Clamp Type, excluding nut RJT Screw Type (BS 1864), including nut ISS Screw Type (ISO 2853), including nut Clamp Type (ISO 2852), excluding clamp DIN Screw Type (DIN 11851), including nut</p>	S1 S2 S3 S4 S5 S6
<p><u>Nominal Line Size</u> 25 mm (1 in) 40 mm (1.5 in) 50 mm (2 in) 65 mm (2.5 in) 80 mm (3 in) 100 mm (4 in)</p>	A B C D E F
<p><u>Sensor Sensitive Length (X)</u> 75 mm (3 in) 150 mm (6 in)</p>	R T
<p><u>Connecting Tubing Length</u> 1 m (3.5 ft) 3 m (10 ft)</p>	N P
<p>Examples: 12A; 12A-C; 12A-H; 12AS-3242S1BRN</p>	

(a)Connector codes S1 and S2 meet U.S. sanitary code; S3, S4, and S5 meet British sanitary code; S6 meets German sanitary codes.

PERFORMANCE SPECIFICATIONS

(12A and 12AS Series with range limits, spans, and sensitive lengths as noted by asterisks in Table 1.)

Accuracy

Includes Linearity, hysteresis, and repeatability
±0.5% of span.

Repeatability

0.2% of span.

Dead Band

0.05% of span.

Supply Pressure Effect

The zero shift is less than 0.2% of span for a 5% change in supply pressure.

Ambient Temperature Effect

The output error is less than 0.75% of span at midscale for a 28°C (50°F) change between 0 and 55°C (32 and 130°F).

Barometric Pressure Effect

The output error is less than 0.25% of span for a change of 7 kPa (2 inHg, 50 mmHg, or 70 mbar) in barometric pressure.

FUNCTIONAL SPECIFICATIONS

Table 1. Range Limits, Spans, and Maximum Overrange Temperatures (Maximum ORT)

Model Code	Sensor Sensitive Length (X)		Celsius (°C)				Fahrenheit (°F)			
			Range Limits		Span	MAX ORT	Range Limits		Span	MAX ORT
			Lower	Upper			Lower	Upper		
12A* and 12AS*	150	6	-75	+125	25	125	-100	+330	50	330
			-75	+460	50	460	-100	+1000	100	1000
			-75	+550	75	550	-100	+1000	125	1000
			-75	+550	100	550	-100	+1000	150	1000
			-75	+550	100	550	-100	+1000	200	1000
12A and 12AS	75	3	-75	+70	25	125	-100	+150	50	330
			-75	+300	50	460	-100	+650	100	1000
			-75	+550	75	550	-100	+850	150	1000
			-75	+550	100	550	-100	+1000	200	1000
	75 or 150	3 or 6	-75	+550	150	550	-100	+1000	250	1000
			-75	+550	200	550	-100	+1000	300	1000
150	6	-75	+550	200	550	-40	+1000	400	1000	
		0	+550	300	550	0	+1000	500	1000	
12A-C	150	6	-210	+125	25	125	-350	+330	50	330
			-220	+200	50	320	-350	+400	100	600
			-170	+320	100	330	-300	+600	150	600
			-140	+320	150	320	-250	+600	200	600
			-95	+320	200	320	-200	+600	250	600
			-95	+320	200	320	-150	+600	300	600
	75	3	-160	+320	100	320	-250	+600	200	600
			+350	+760	200	760	+600	+1400	400	1400
			+250	+760	300	760	+500	+1400	500	1400
			+150	+760	400	760	+400	+1400	600	1400
150	6	+350	+760	200	760	+600	+1400	400	1400	
		+250	+760	300	760	+500	+1400	500	1400	
		+150	+760	400	760	+400	+1400	600	1400	
		+150	+760	400	760	+300	+1400	700	1400	
						+200	+1400	800	1400	

*See Performance Specifications section.

FUNCTIONAL SPECIFICATIONS (CONT.)
Step Response Time

General purpose thermal system and agitated water bath. Maximum of 12 seconds for a 90% recovery from an input step change on a bare sensor, and less than 2 seconds for a 63% recovery.

Shock Resistance

The 12A Series transmitters meet the requirements for Grade A, Hull mounted Class 1, light-weight, Type A tests as set forth in MIL-S-901C (NAVY) for high impact shock testing. This refers only to the application of testing procedures, and results obtained therefrom, and not to any other part or parts of MIL-S-901C.

Mounting

A universal mounting bracket is supplied for mounting the transmitter on a surface or on a DN 50 or a 2 in pipe. The mounting position is unrestricted.

Ambient Temperature Limits

-35 and +180°C (-30 and +180°F). The vinyl covered portion of the connecting tubing must be in an area between -55 and +105°C (-65 and +220°F).

Supply Pressure

140 kPa, 20 psi, 1.4 bar or kg/cm², ±10%. The supply air must have a dew point at least 10°C (18°F) below the expected operating ambient temperature.

Air Connections

The supply and output connections are tapped for 1/4 NPT.

Output Signal

20 to 100 kPa, 3 to 15 psi, or 0.2 to 1.0 bar or kg/cm², as specified.

Air Consumption under Normal Operation

0.5 m³/h (0.3 cfm) at standard conditions.

PHYSICAL SPECIFICATIONS**Body**

Die-cast low copper aluminum alloy with baked gray vinyl finish.

Cover

Blue, high-impact, glass-filled polycarbonate.

Environmental Protection

The transmitter housing is weatherproof. It is dust-protected as defined in IEC IP54 and, with its constant air purging, provides the environmental protection of NEMA Type 3.

Thermal System

SAMA (Scientific Apparatus Makers Associations) Class IIIB case-compensated gas-filled thermal system.

Connection Tubing

Vinyl covered AISI Type 302 stainless steel (302 ss) flexible armor over 316 ss capillary. The length is 1 mm (3.5 ft).

Bushings

Fabricated of 316 ss and available with R 1/2, R 3/4, R 1, G 1/2 B, G 3/4 B, G 1 B, 1/2 NPT, 3/4 NPT, or 1 NPT external thread and 1-18 NS internal thread. Supplied with transmitter when a well is not required.

Mass

Approximate 2.8 kg (6.3 lb) with general purpose thermal system and bushing.

Date Plate

Aluminum data plate fastened to topworks cover with pressure sensitive adhesive. Includes space for customer tag data up to a maximum of 121 characters and spaces. For additional space, see optional Customer Tag.

Sensor

Has adjustable union and bendable extension (see Figure 1). Jam nut has external 1-18 UNS thread. All process-wetted parts are 316 ss except for Code 12A-H, which has an Inconel sensor and bendable extension. Also, Code 12A-H has a fixed union.

DIAMETER (Y)

9.53 mm (0.375 in)

SENSITIVE LENGTH (X)

150 mm (6 in)

EXTENSION LENGTH (J)

450 mm (18 in). The J dimension for the 12A-H Series must be long enough to limit temperature of capillary tubing to 105°C (220°F).

INSERTION LENGTH (U)

200 to 530 mm (8 to 21 in), adjustable.

IMMERSION LENGTH (R)

As specified.

PHYSICAL SPECIFICATIONS (CONT.)

Adjustable Union Packaging

ptfe

For maximum pressure of 7 MPa (1000 psi) at maximum temperature of 205°C (400°F).

MATERIAL GRAPHITE

For maximum pressure of 7 MPa (1000 psi) at maximum temperature of 205°C (400°F), and diminishing linearly to a pressure of 0.7 MPa (100 psi) at a maximum temperature of 540°C (1000°F).

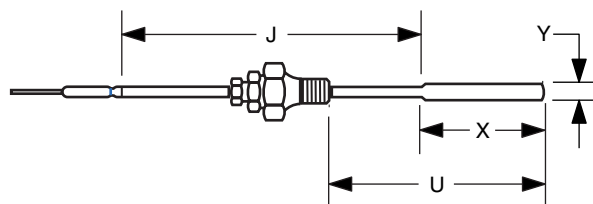

Figure 1. Plain Bendable Sensor with Adjustable Union

OPTIONAL FEATURES

(When ordering an option, add Sensor Code or Auxiliary Specification (AS) Reference to Model Code. Example: 12A-C, AS Reference DU. When an AS Reference is not given, use comment shown in column.)

Table 2. Optional Features

Optional Feature	Description	Sensor Code or AS Reference
Customer Tag	Stainless steel tag wired to transmitter for customer tag data that does not fit on data plate. There can be a maximum of 10 lines of data with 40 characters or spaces per line.	MTS
Intermediate Spans	Spans other than those listed Table 1 are available.	Specify Span
Longer Connection Tubing	Maximum overall length, including (J) length, for 150 mm (6 in) sensors is 6 m (20 ft), and for 75 mm (3 in) sensors is 3 m (10 ft)	–
Optional Dimensions for Adjustable Union Sensor	<p>Extension Length (J) Minimum = 300 mm (12 in); and maximum = as required.</p> <p>Insertion Length (U) Maximum = (X) plus 50 mm (2 in); and maximum = (J) plus X – 75 mm (3 in).</p> <p>Sensor Sensitive Length Diameter (Y) 12.7 mm (0.50 in) for use with a well having a 13.0 mm (0.51 in) bore; 9.27 mm (0.365 in) for use with a well having a 9.53 mm (0.375 in) bore.</p> <p>Bushing Fabricated of 316 ss and available with R 1, R 1-1/4, G 1 B, or 1 NPT external thread and 1-1/4 18NS internal thread.</p> <p>Jam Nut With 1-1/4 18 thread.</p>	Specify Dimension
Fixed Union Sensors	Fixed union with bendable extension, fabricated of 316 ss. The sensor sensitive lengths are listed in Table 1 (same as for standard sensors)	Sensor Code 3442
Plain Capillary Sensors	<p>316 ss construction, 3.2 mm (0.125 in) diameter, 2.5 m (8 ft) minimum length. Shipped in a coil 100 mm (4 in) internal diameter.</p> <p>Like Code 3940-40 except; sensor diameter is 6 mm (0.25 in), minimum length is 5 m (15 ft), and adjustable union included. Shipped in a coil 100 mm (4 in) internal diameter and available in 316 ss or Inconel.</p> <p>316 ss</p> <p>Inconel</p>	<p>Sensor Codes 3940-40</p> <p>3941-40</p> <p>3981-40</p>

Table 2. Optional Features (Continued)

Optional Feature	Description	Sensor Code or AS Reference
Preformed Capillary Sensors	<p>Identical to Code 3940-40 except wound in spring-like coils to the following internal diameters:</p> <ul style="list-style-type: none"> 25 mm (1 in) 40 mm (1.5 in) 50 mm (2 in) 65 mm (2.5 in) <p>Same as above except sensor diameter is 6 mm (0.25 in). Available in 316 ss or Inconel wound to the internal diameters shown:</p> <p>316 ss</p> <ul style="list-style-type: none"> 25 mm (1 in) 40 mm (1.5 in) 50 mm (2 in) 65 mm (2.5 in) <p>Inconel</p> <ul style="list-style-type: none"> 25 mm (1 in) 40 mm (1.5 in) 50 mm (2 in) 65 mm (2.5 in) 	<p>Sensor Codes</p> <ul style="list-style-type: none"> 3740-10 3740-15 3740-20 3740-25 3741-10 3741-15 3741-20 3741-25 3781-10 3781-15 3781-20 3781-25
Air Supply Sets	<p>These are available as fixed or adjustable combination pressure regulator and filter with a nominal 50 mm (2 in) pressure gauge graduated 0 to 200 kPa, 0 to 30 psi, or 0 to 2 bar or kg/cm², mounted and piped to transmitter using bright nickel-plated or PVC-coated tubing, as specified. Fixed pressure regulators without gauges are also available. Maximum input pressure is 1 MPa (150 psi, or 10 bar or kg/cm²).</p>	<p>IAS-F (Fixed, no gauge) IAS-FG (Fixed, with gauge) IAS-AG (Adjustable, with gauge)</p>
Sausage-Type Sensors for Flue Gas Applications	<p>For measurement of gas temperature in ducts or flues between 2 and 5 m (6.5 and 15 ft) wide. The sensor has a fixed union with a bendable extension and is fabricated of 316 ss. The sensitive sections are 9.53 mm (0.375 in) diameter and 300 mm (12 in) long separated by neck links 6 mm (0.25 in) diameter and 100 mm (4 in) long. The bushing is R1/2 or 1/2 NPT. A perforated pipe, supplied and installed by the user, is required for supporting the sensor across the duct.</p>	Sensor Code 3042
Wells	<p>Selection of designs and materials available to suit requirements of virtually any application. Recommended (U) dimension is the sensor sensitive length (X) plus a minimum of 50 mm (2 in) to minimize conduction losses (Refer to PSS 3-3C1 A for further details.)</p>	–
Derivative Unit	<p>This attachment reduces time lag of measurement and is adjustable. (Refer to TI 37-9a for further details.)</p>	DU
Well Mounting Bracket	<p>Special bracket for mounting transmitter directly to well.</p>	WMB
Test Tee	<p>A T-connector tapped for 1/4 NPT and fitted with a shut-off valve is mounted on the transmitter for monitoring the output signal.</p>	OTT
Bushing	<p>Plain, 316 ss with external thread per British Standard 21 and 2779.</p>	–
Replacement Thermal System	<p>Consists of sensor with 1 or 3 m (3.5 or 10 ft) of tubing, element capsule, and separate compensating bellows. Range spring included only if specified. Calibrated range and output signal must be specified.</p>	–

DIMENSIONS – NOMINAL

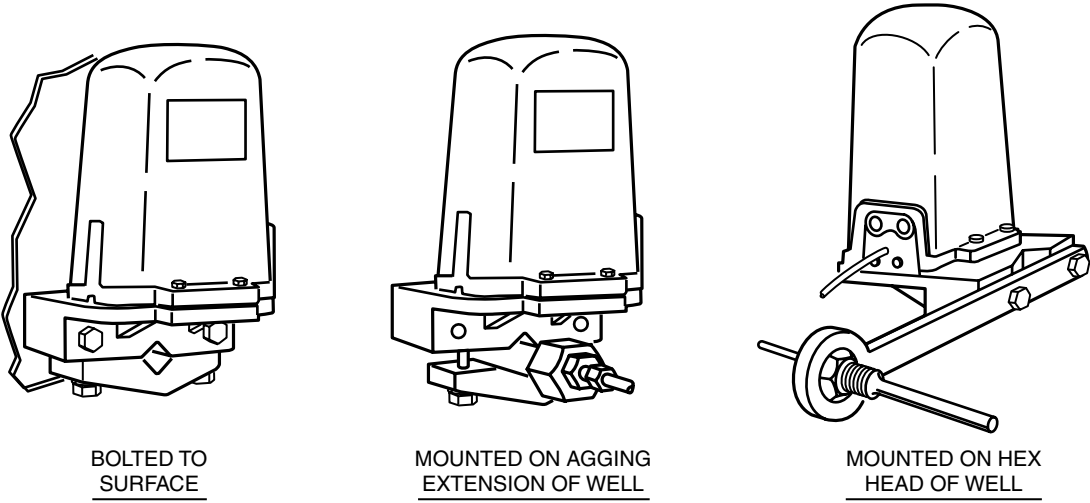
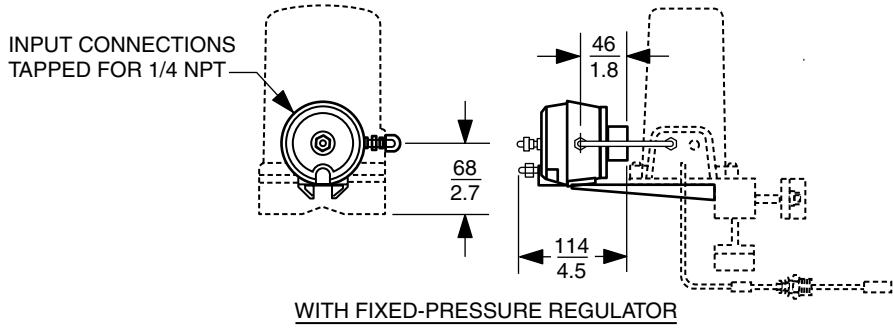
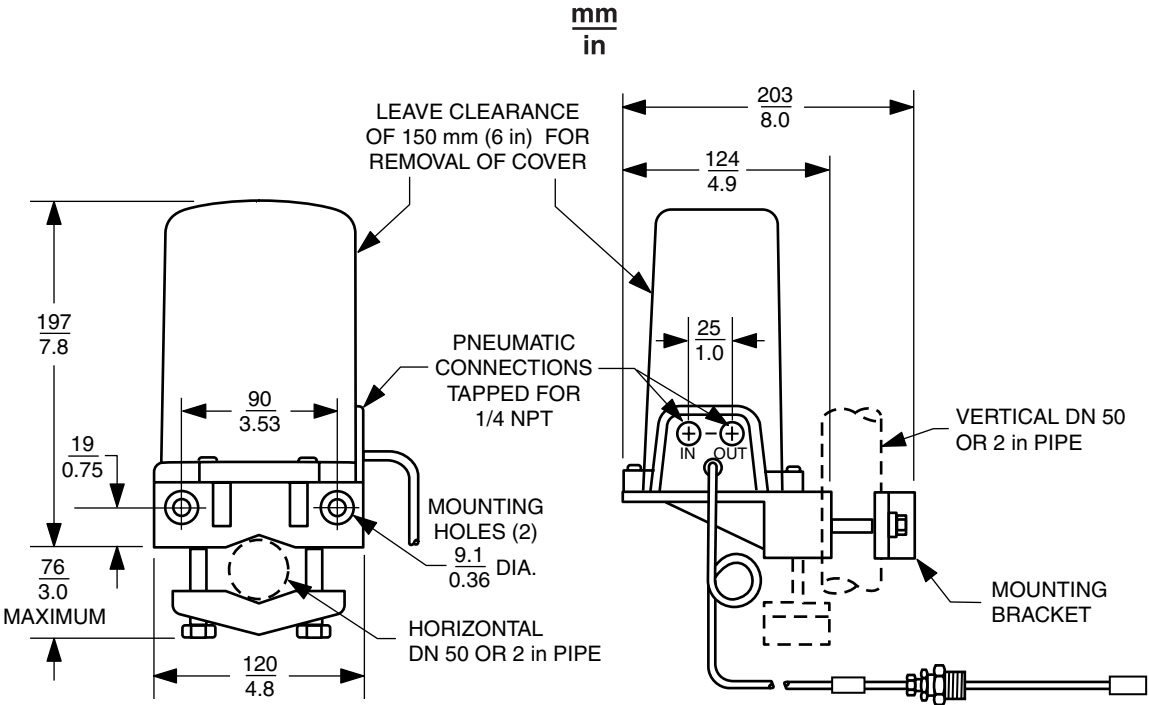

ORDERING INSTRUCTIONS

1. Model Code
2. Output Signal
3. Range Limits and Span
4. Calibrated Range
5. Sensor Code (3542 for 12A and 12A-C Series, 3482 for 12A-H Series)
6. Connecting Tubing Length (12A, 12A-C and 12A-H Series only; 12AS length is specified by Model Code)
7. Sensor Dimensions:
 - Diameter (Y)
 - Sensitive Length (X)
 - Extension Length (J)
 - Insertion Length (U)
 - Immersion Length (R)
8. Bushing External Thread Size
9. Optional Features
10. Tag and Application

The Foxboro Company
33 Commercial Street
Foxboro, MA 02035-2099
United States of America
<http://www.foxboro.com>
Inside U.S.: 1-888-FOXBORO
(1-888-369-2676)
Outside U.S.: Contact your local
Foxboro representative.
Facsimile (508) 549-4492

An Invensys company

Foxboro is a registered trademarks of The Foxboro Company.
Invensys is a trademark of Invensys plc.
All other brand names may be trademarks of their respective companies.

Copyright 1979- 2001 The Foxboro Company
All rights reserved

MB 010

Printed in U.S.A.

0201